

<sup>1</sup>Rakeshkumar  
Dilipkumar Modi  
<sup>2</sup>Dr. Maulik Raichura

## Renewable Energy Source Integrated Hybrid Energy Storage System for Electric Vehicle



**Abstract:** - In order to meet the need for charging electric vehicles, this article explored the concept of renewable energy sources such as solar photovoltaic systems (PV systems) coupled with battery storage systems (BSB) and super capacitors. Using MATLAB simulation and findings, this article also focusses on the relationship between RES and HESS and how they work together to charge electric vehicles. Here, we are using a Proportional Integral Controller (PI Controller) to regulate the DC-DC converter's output for both HESS and electric vehicle charging.

**Keywords:** Renewable Energy Source (RES), Hybrid Energy Storage System (HESS), Electric Vehicle Charging System (EVCS), Photo Voltaic (PV), Proportional Integral (PI).

### I. INTRODUCTION

The Electric Vehicle Charging System (EVCS) as shown in **Figure – 1** was proposed in this research work. Electric vehicles that are parked during the day at home or at work are meant to be charged by a system. This system's goal is to maximize the amount of solar photovoltaic energy used for charging electric vehicles. The system design is predicated on supercapacitors, EVs, PVs, and BSBs as per specifications is shown in **Table – 1.**[2]

### II. ARCHITECTURE OF PROPOSED ELECTRIC VEHICLE CHARGING SYSTEM (EVCS)

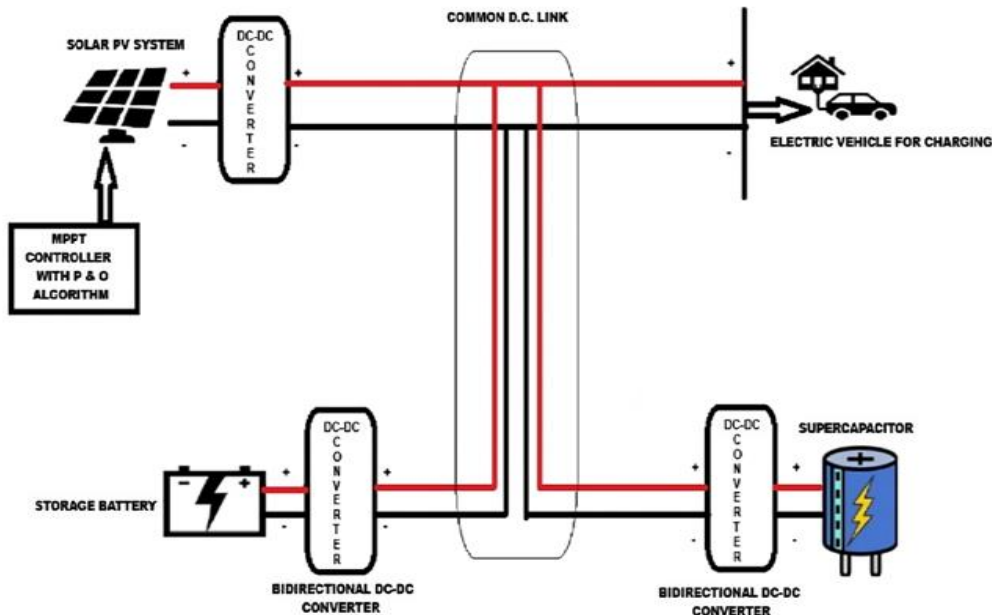

**Figure – 1** Architecture of proposed Electric Vehicle Charging System (EVCS)

<sup>1</sup> \*Corresponding author: K. D. POLYTECHNIC, PATAN AND MONARK UNIVERSITY, VAHELEL, AHMEDABAD

<sup>2</sup> HASMUKH GOSWAMI COLLEGE OF ENGINEERING, MONARK UNIVERSITY, VAHELAL, AHMEDABAD

Copyright © JES 2024 on-line : journal.esrgroups.org

**III. SPECIFICATIONS OF ELEMENTS USED IN PROPOSED EVCS**

| Sr. No. | Element         | Specifications   |
|---------|-----------------|--|
| 1       | Solar PV Panel  | Power Rating: 1000 Watts (1KW)<br>Voltage Rating: 50 Volts<br>Temperature: 25° C<br>Solar Irradiance: 480 W/m <sup>2</sup>   |
| 2       | Storage Battery | Type of Battery: Lithium Iron<br>Capacity: 60 Kwh<br>Voltage: 50 Volts<br>Cycle Life: 1500 cycles<br>Energy density: 250 Wh/Kg<br>Power density: 3 Kw/L<br>Operating temp.: -10°C to 45°C  |
| 3       | Supercapacitor  | No. of Series Capacitor = 6<br>No. of Parallel Capacitor = 1<br>Capacitance = 500 (F)<br>D.C. Series Resistance = $2.1 \times 10^{-3}$ Ohm<br>Operating temp. = 25°C   |
| 4       | PWM Generator   | Purpose: Generate PWM signal to control DC-DC Converter<br>Switching Frequency = 20 KHz<br>Duty cycle = 0 % to 100 %<br>Control Signal I/P: Accept I/P from PI controller to determine PWM duty cycle<br>Dead time: Minimum delay between switching transistors to prevent shoot (1 Micro second).<br>Output stage: MOSFET with power switch<br>Resolution = 12 bits |
| 6       | MOSFET          | Ron = On Resistance = 0.1 Ohm<br>Lon = Inter diode inductance = 0 H<br>Rd = Internal diode resistance = 0.01 Ohm<br>Internal diode forward voltage = 0 V   |
| 7       | Snubber Circuit | ON state diode resistance = 0.001 Ohm<br>OFF state diode resistance = Infinite<br>Diode forward voltage = Vf = 0.8 Volts<br>Rs = Snubber resistance = 500 Ohms<br>Cs = Snubber capacitance = $250 \times 10^{-9}$ F  |

**Table – 1 Specifications of Elements of proposed EVCS**

**IV. ELEMENTS OF PROPOSED EVCS**

The following are the main components of proposed Electric Vehicle Charging System (EVCS).[5]

- (1) RES/Solar PV System (Renewable Energy System)
- (2) MPPT (Maximum Power Point Tracking) Controller
- (3) P&O (Perturb & Observe) Algorithm
- (4) BSB (Battery Storage System)
- (5) Supercapacitor
- (6) Bidirectional DC-DC Converter

**(1) RES/Solar PV System (Renewable Energy System):**

- RES are renewable energy system that generate electricity from renewable energy source like Solar PV panels, Wind Power plant etc.[6]
- Electricity generated by RES are used to offset the electricity demand where RES are installed.[6]
- RES depends on renewable sources like Solar PV panel generation depends on amount of sunlight. So, they require integration with storage system or grid flexibility to manage variability and ensure grid stability.[6]

**(2) MPPT (Maximum Power Point Tracking) Controller:**

- Each solar panel has a specific operating point where it can generate maximum power output for a given amount of sunlight that point is called MPP (Maximum power point). This MPP variation depending on sunlight and temperature.[7]

- MPPT controller is an electronic device that continuously adjust the operating voltage and current of solar panel to ensure that solar panel operate at its maximum power point. This is achieved by tracking changes in the output of the solar panel and adjusting its electrical operating point.[7]

**(3) P&O (Perturb & Observe) Algorithm:**

- MPPT controllers use various algorithms to find and lock MPP of solar PV panel. Here we have used P & O (Perturb & Observe) algorithm. Perturb means to change.[8]
- P & O algorithm is a popular method used in MPPT controllers for solar PV system.[8]
- P&O algorithm continuously modifies solar PV system operating point and tracks impact on solar panel power output. When the MPP is met or marginally exceeded, it modifies the operating point so that the solar panel's power output increases.[8]
- P & O algorithm measures the power output of the solar PV panel at regular intervals like every few Milli seconds to seconds depending on the implementation.[8]
- A tiny quantity (called a perturbation) is changed by the controller to the solar PV system's operational point. This allows the solar panel's voltage or current to be adjusted.[8]
- After perturbation the algorithm observed whether power output of the solar panel increased or decreased compare to the previous measurement. Decision is based on observed change in power output.[8]
- The overall efficiency of the solar PV system is raised when it is operated at its maximum power point.[8]

**(4) BSB (Battery Storage System):**

- RES or grid-supplied electricity is stored by BSB for future use. Surplus electricity produced at periods of low demand or high generation from renewable energy sources is stored by BSB. When demand is high or there is a deficiency in renewable energy generation, this energy can be employed.[9]
- BSB can optimize self-consumption of RES by storing excess generation for use during peak demand period reducing reliance on grid electricity and lowering energy cost.[9]

**(5) Supercapacitor (Ultracapacitor):**

- Maximizing the contact surface area of an ultra-capacitor is required to raise its capacitance. One needs to employ a certain material for the electrode in order to accomplish this without increasing the volume of the capacitor.[10]
- This substance needs to be porous in order to have a very high specific surface. Carbon nanotubes or activated carbon are the most commonly utilized materials.[10]

**(6) Bidirectional DC-DC Converter:**

- Bidirectional DC-DC converters can transfer power in both directions and are used to increase or decrease the DC voltage between their input and output.[5]
- Bidirectional DC-DC converters find several applications in fuel cell storage systems, renewable energy storage systems, hybrid vehicle energy storage systems, and uninterruptible power supplies.[11]
- They have typically been used in motor drives for regenerative braking and speed regulation. When bidirectional power flow capability and DC bus voltage management are required, bidirectional DC-DC converters are used.[11]

**V. PROPORTIONAL INTEGRAL CONTROLLER (PI CONTROLLER)**

| ASPECTS                          | FEATURE OF PID CONTROLLER                 |
|----------------------------------|---|
| <b>Controller Components</b>     | Proportional and Integral (no Derivative) |
| <b>Control Actions</b>           | Proportional and Integral actions         |
| <b>Steady-State Accuracy</b>     | Good                                      |
| <b>Response Speed</b>            | Moderate                                  |
| <b>Transient Response</b>        | Moderate (May exhibit overshoot)          |
| <b>Disturbance Rejection</b>     | Good (With Integral)                      |
| <b>Noise Sensitivity</b>         | Low (No Derivative)                       |
| <b>Tuning Complexity</b>         | Simple                                    |
| <b>Tuning Sensitivity</b>        | Less Sensitive (Two Gains)                |
| <b>Stability Concerns</b>        | Generally Stable                          |
| <b>Application Suitability</b>   | Steady-State Accuracy                     |
| <b>Implementation Simplicity</b> | Simple Hardware/Software Integration      |
| <b>Optimal for</b>               | Applications with Moderate Dynamics       |

**Table – 2 Aspects and Features of PI Controller**

**VI. WORKING OF PROPOSED EVCS**

- Solar PV panel, storage battery and Supercapacitor are tied with Common D.C. link through Bidirectional DC-DC Converter.[13]

- Solar PV panels generate electric power for charging Electric vehicle and it operates at MPP with help of MPPT controller and P & O algorithm.[1]
- When generation of Solar PV system is low during electric power demanded by electric vehicle, PI controller checks, the features of PI controller is shown in **Table – 2**, SOC of battery first and if SOC of battery is more than 20% to 80%, storage battery will fulfil charging power to electric vehicle.[1]
- If SOC of storage battery is less than 20% then Supercapacitor will provide electric power to charge electric vehicle.[1]
- During sufficient generation of electric power by RES (Solar PV system), it will charge electric vehicle as well as storage battery and supercapacitor.[1]
- Voltage of Common D.C. link will maintain constant with the help of DC-DC converter.[1]

**VII. METHODOLOGY**

Here, we have used MATLAB Simulation to establish the relationship between RES and HESS and how they work together to charge electric vehicles. **Figure – 2** shows the MATLAB Simulink model of solar PV based Battery Management System (BMS).

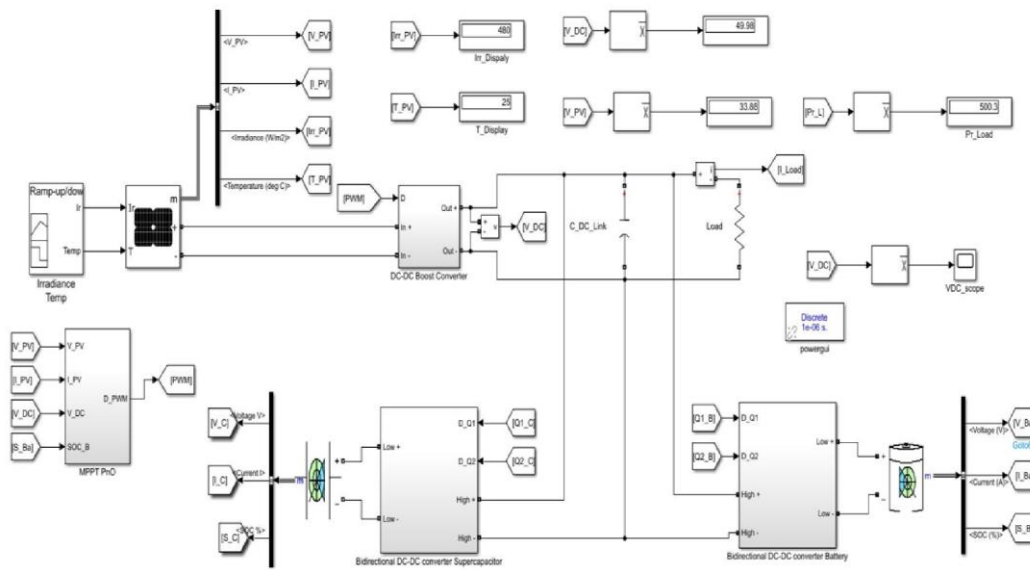

**Figure – 2 MATLAB Simulink model of solar PV based BMS**

Figure – 3 shows MATLAB Simulink model of MPPT controller and Boost converter Circuit.

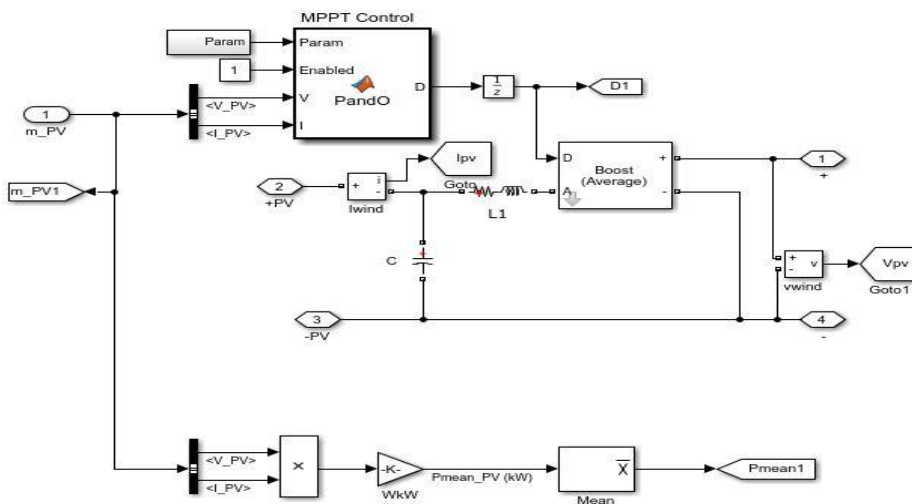

**Figure – 3: MATLAB Simulink model of MPPT controller and Boost converter Circuit**

Figure – 4 shows MATLAB Simulink model of Subsystem for Power Calculation from all Sources.

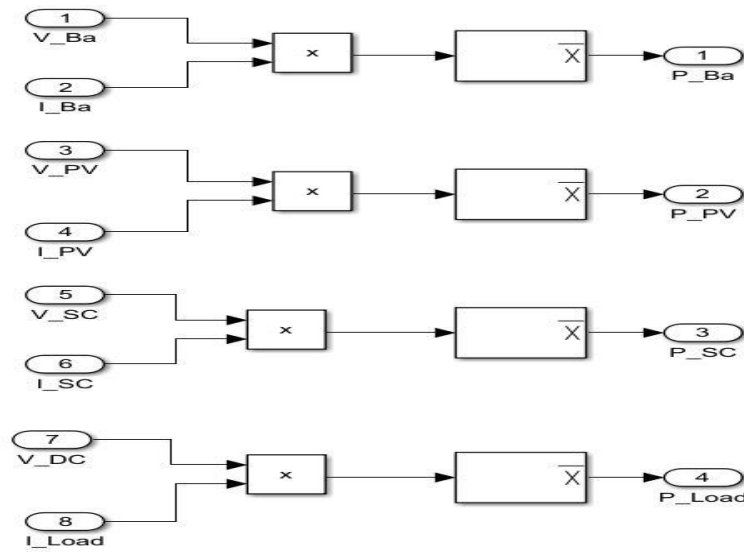

Figure – 4: MATLAB Simulink model of Subsystem for Power calculation from all sources

Figure – 5 shows MATLAB Simulink model of PI controller based BMS controlling system

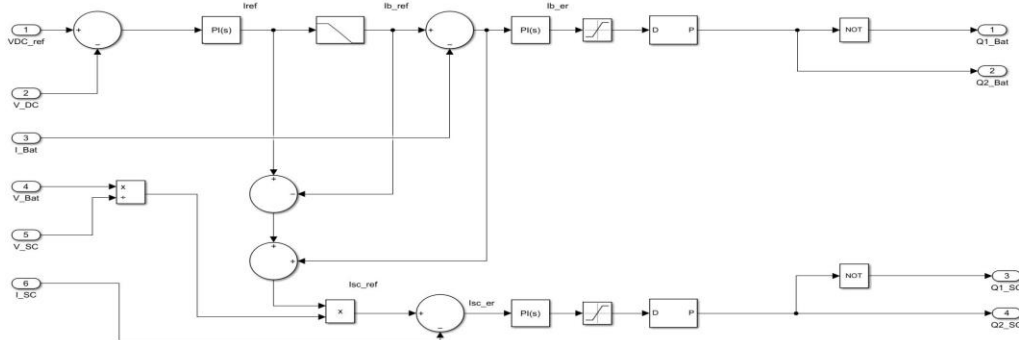
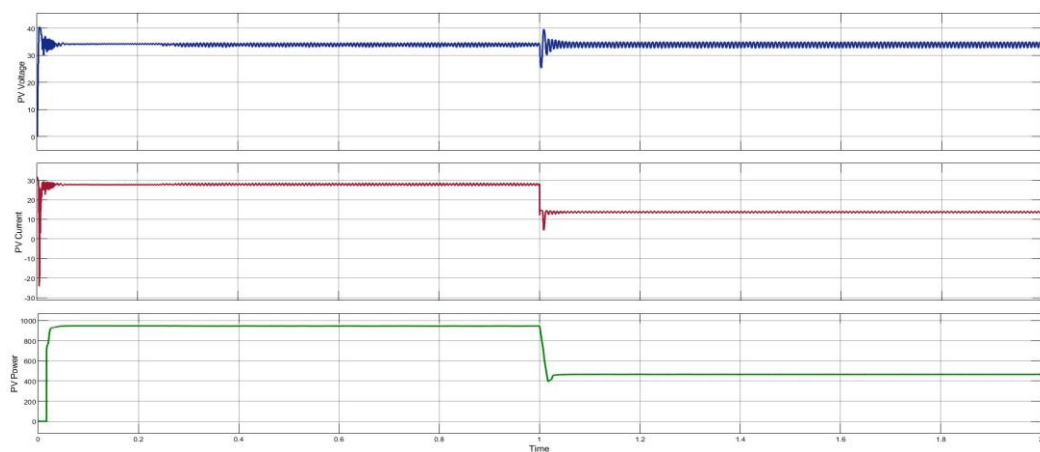

Figure – 5: MATLAB Simulink model of PI controller based BMS controlling system

## VIII. MATLAB SIMULATION RESULTS WAVEFORMS

### Waveform-1: Simulation Result of Solar PV Output Parameters



**Waveform-2: Simulation Result of Battery output parameters with BMS**

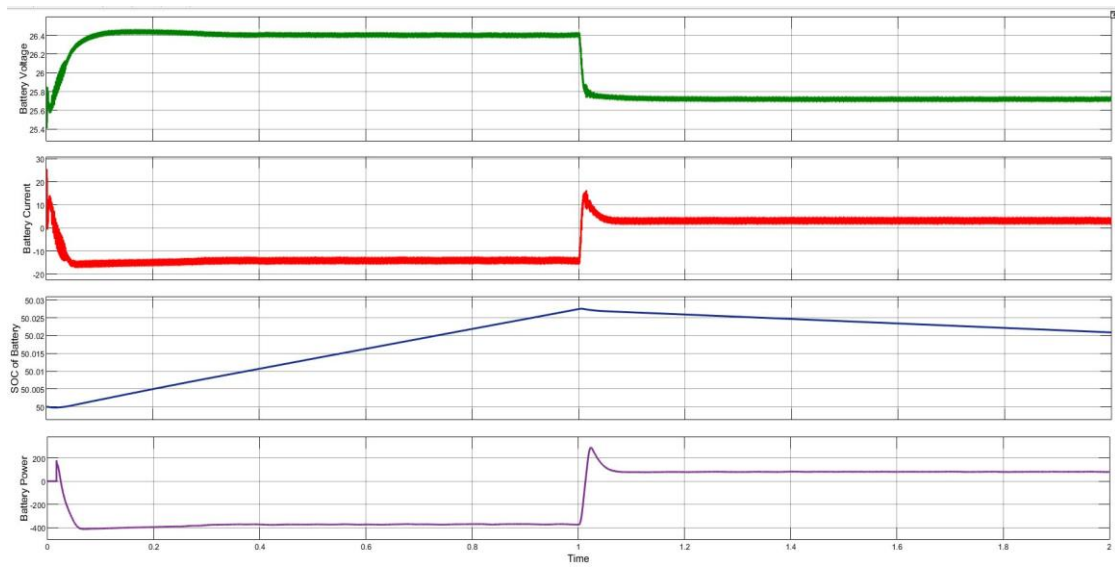

**Waveform-3: Simulation Result of Supercapacitor output parameters**

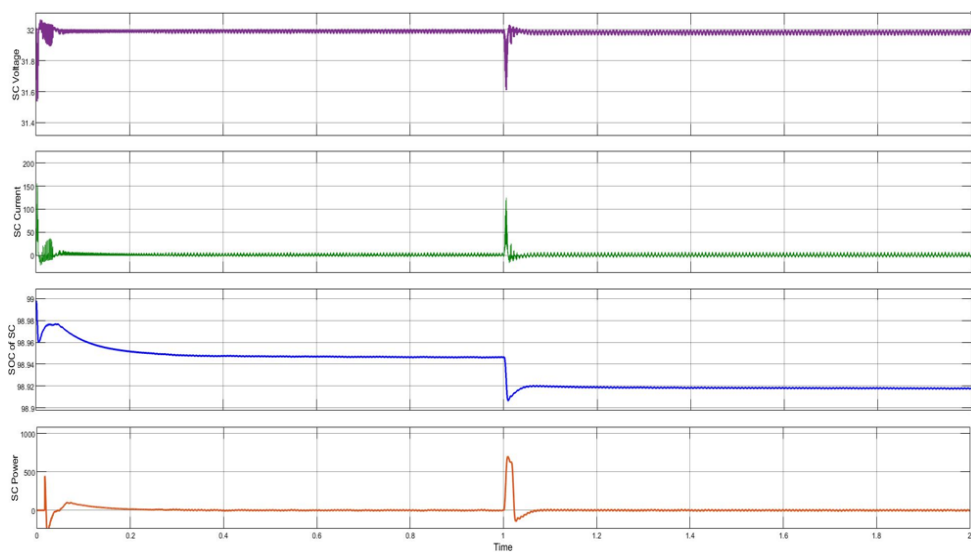

**Waveform-4: Simulation Result of Power Variation from all Power Sources**

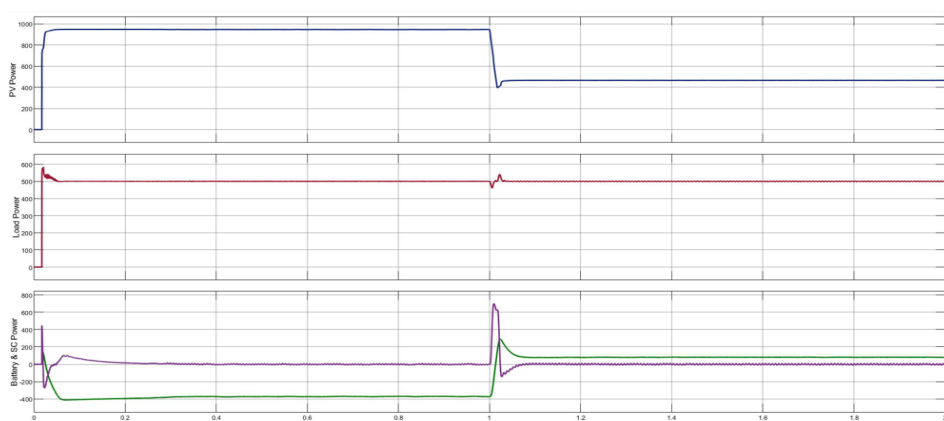

**Waveform-5: Simulation Result of Common D.C. Link Capacitor**

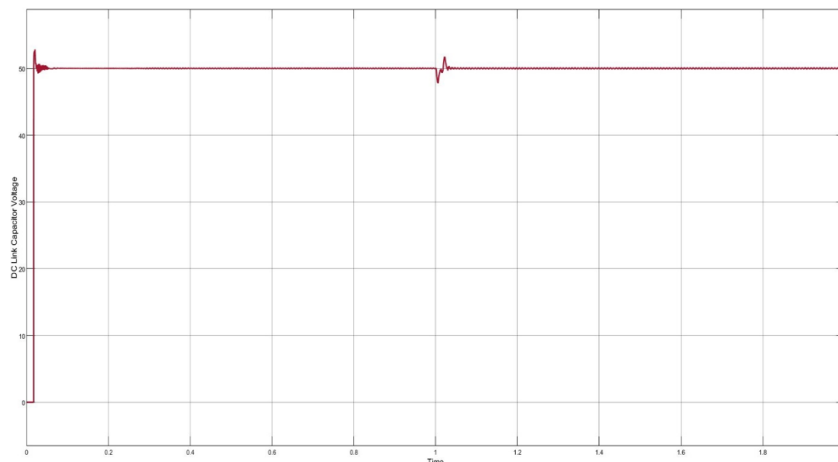

**IX. MATLAB SIMULATION RESULT ANALYSIS**

| Sr. No. | Waveform of Results | Result Summary   |
|---------|---------------------|--|
| 1       | Waveform-1          | It indicates that the solar PV panel's voltage is 33.85 volts and its current is 29 amps. 500.3 Watts of power at 480 W/m <sup>2</sup> of PV irradiance and 25 degrees Celsius of solar panel temperature are produced by the solar panel.[13]   |
| 2       | Waveform-2          | It displays data about storage batteries, including voltage, current, state of charge, and power supplied to electric vehicles. Batteries will charge when renewable energy sources (RES) are produced in sufficient amounts; when RES generation is insufficient, batteries will supply the energy needed to charge electric vehicles.[13]  |
| 3       | Waveform-3          | It displays the supercapacitor's output parameters, including voltage, current, SOC, and power output. As we can see, the supercapacitor charges when the power from the solar PV system is sufficient. However, when the RES's energy generation is low, the supercapacitor will supply the extra power needed to charge an electric vehicle.[13]                                       |
| 4       | Waveform-4          | The power variation of the supercapacitor, storage battery, and solar PV system is displayed. According to the waveform, the power required by an electric vehicle is always 500.3 watts. When solar power generation is low, storage batteries and supercapacitors are in charging mode and deliver power based on the storage battery and supercapacitor's state of charge (SOC%).[13] |
| 5       | Waveform-5          | It indicates that the voltage of the common D.C. connection does not change during the DC-DC converter.[13]  |

**Table – 3 Result analysis and summary of proposed EVCS**

**X. CONCLUSION**

- Integration of Renewable Energy Source with Battery Storage System and Supercapacitor will increase the use of Solar energy to charge electric vehicles, decrease the dependence of the charging system on the Battery Storage System, and also extend the life of the Battery Storage System, according to the result analysis displayed in **Table – 3**.[14]
- The cost of charging an electric vehicle is reduced by the proposed solution.[15]

**XI. FUTURE SCOPE**

- This system can tie with grid to make Grid tied RES for allowing excess electricity generated by RES fed back into the grid.[13]
- This makes consumers to get benefit by rebate.[13]
- Grid tied RES can manage variability and ensure grid stability.[13]

**XII. DECLARATION**

This Research Project is Self-funded.

### XIII. CONFLICT OF INTEREST / DECLARATION OF COMPETING INTEREST

On behalf of all the authors, the corresponding author states that there is no conflict of interest. This Research project is Self-funded.

### XIV. REFERENCES

- [1] Z. Amjadi and S. S. Williamson, "Review of alternate energy storage systems for hybrid electric vehicles," *2009 IEEE Electr. Power Energy Conf. EPEC 2009*, pp. 1–32, 2009, doi: 10.1109/EPEC.2009.5420917.
- [2] M. Yao, D. Da, X. Lu, and Y. Wang, "A Review of Capacity Allocation and Control Strategies for Electric Vehicle Charging Stations with Integrated Photovoltaic and Energy Storage Systems," *World Electr. Veh. J.*, vol. 15, no. 3, 2024, doi: 10.3390/wevj15030101.
- [3] O. A. A. Mohammed, L. Peng, G. H. A. Hamid, A. M. Ishag, and M. A. A. Abdalla, "Effective Energy Management Strategy with Model-Free DC-Bus Voltage Control for Fuel Cell/Battery/Supercapacitor Hybrid Electric Vehicle System," *Machines*, vol. 11, no. 10, 2023, doi: 10.3390/machines11100944.
- [4] K. Raut, A. Shendge, J. Chaudhari, R. Lamba, T. Mallick, and A. Roy, "Performance Analysis of Multiple Energy-Storage Devices Used in Electric Vehicles," *World Electr. Veh. J.*, vol. 15, no. 8, 2024, doi: 10.3390/wevj15080357.
- [5] J. R. Babu, M. R. Nayak, and B. Mangu, "Development and Application of an Energy Management System for Electric Vehicles Integrated with Multi-input DC-DC Bidirectional Buck-Boost Converter," *Int. J. Electr. Electron. Res.*, vol. 11, no. 2, pp. 457–464, 2023, doi: 10.37391/IJEER.110228.
- [6] S. Serag, A. Echchelh, and B. Morrone, "Hydroelectric and Hydrogen Storage Systems for Electric Energy Produced from Renewable Energy Sources Hydroelectric and Hydrogen Storage Systems for Electric Energy Produced," no. August, 2024, doi: 10.32604/ee.2024.054424.
- [7] S. Deem *et al.*, "Optimal Placement of Electric Vehicle Charging Stations in an Active Distribution Grid with Photovoltaic and Battery Energy Storage System Integration," *Energies*, vol. 16, no. 22, 2023, doi: 10.3390/en16227628.
- [8] C. Armenta-déu, "Hybrid Power Source Assisted by Renewable Energies for Hybrid Electric Vehicles Hybrid Power Source Assisted by Renewable Energies for Hybrid Electric Vehicles," 2024, doi: 10.20944/preprints202404.1252.v1.
- [9] Y. Belkhier, A. Oubelaid, and R. N. Shaw, "Hybrid power management and control of fuel cells-battery energy storage system in hybrid electric vehicle under three different modes," *Energy Storage*, vol. 6, no. 1, 2024, doi: 10.1002/est2.511.
- [10] A. S. Samosir and A. H. M. Yatim, "Implementation of dynamic evolution control of bidirectional DC-DC converter for interfacing ultracapacitor energy storage to fuel-cell system," *IEEE Trans. Ind. Electron.*, vol. 57, no. 10, pp. 3468–3473, 2010, doi: 10.1109/TIE.2009.2039458.
- [11] R. P. Narasipuram and S. Mopidevi, "A Novel Hybrid Control Strategy and Dynamic Performance Enhancement of a 3.3 kW GaN–HEMT-Based iL2C Resonant Full-Bridge DC–DC Power Converter Methodology for Electric Vehicle Charging Systems," *Energies*, vol. 16, no. 15, 2023, doi: 10.3390/en16155811.
- [12] R. A. Khan, N. Islam, S. Ahmad, B. Sabir, M. A. Husain, and H. Liu, "Advances in Solar PV-Powered Electric Vehicle Charging System," *Photovolt. Syst. Technol.*, pp. 63–83, 2024, doi: 10.1002/9781394167678.ch4.
- [13] A. Šare, G. Krajačić, T. Pukšec, and N. Duić, "The integration of renewable energy sources and electric vehicles into the power system of the Dubrovnik region," *Energy. Sustain. Soc.*, vol. 5, no. 1, 2015, doi: 10.1186/s13705-015-0055-7.
- [14] C. A. Buckner *et al.*, "We are IntechOpen , the world ' s leading publisher of Open Access books Built by scientists , for scientists TOP 1 %," *Intech*, vol. 11, no. tourism, p. 13, 2016, [Online]. Available: <https://www.intechopen.com/books/advanced-biometric-technologies/liveness-detection-in-biometrics>
- [15] Z. Zhu, F. Xiao, Z. Huang, J. Liu, P. Chen, and Q. Ren, "Bidirectional Power Control Strategy for Super Capacitor Energy Storage System Based on MMC DC-DC Converter," *IEEE Access*, vol. 10, pp. 53225–53233, 2022, doi: 10.1109/ACCESS.2022.3175207.

### AUTHORS:

#### Author – 1: RAKESHKUMAR DILIPKUMAR MODI (Corresponding Author)

Post of Author-1: Lecturer in Electrical Engineering Department of K. D. Polytechnic, Patan & Research Scholar at Monark University

Affiliation: K. D. Polytechnic, Patan & Monark University

email Id: [sonu.4284@yahoo.co.in](mailto:sonu.4284@yahoo.co.in)

#### Author – 2: Dr. MAULIK RAICHURA

Post of Author-2: Assistant Professor of Electrical Engineering Department

Affiliation: Hasmukh Goswami College of Engineering, Vahelal, Ahmedabad

email: [maulik.raichura.foet@monarkuni.ac.in](mailto:maulik.raichura.foet@monarkuni.ac.in)