

¹*Ramesh²Mohd. Khurshed³Bindeshwar Singh

Optimal Integration for DGs with EVs planning in Distribution Networks with Hybrid MC-GA Technique using Realistic Load Models



Abstract: -With the growing integration of Distributed Generations (DGs) and Electric Vehicles (EVs) into distribution grids, the need for efficient and intelligent management strategies has become paramount. The need for power consumption is increasing every day in accordance with the standard demand pattern. As a result, either creating a lot of electricity or minimizing losses is crucial. In order to minimize real and reactive power losses from the system's point of view, this paper presents the optimal performance index-based size and location determination of DGs, EVs and their coordination in distribution networks using realistic load models (RLMs) such as RLM-1, RLM-2, RLM-3, RLM-4, and RLM-5, respectively. Improvement of the system power factor (SPF) is defined in this analysis as the power system's performance both with and without different kinds of DGs and DGs with EVs for various RLMs. PHEVs type of EVs used in this paper. The hybrid Monte Carlo-Genetic Algorithm (MC-GA) is the basis of the simulation technique that is being suggested. Networks with IEEE-16 and 37 buses in their distribution systems have been used to test the suggested methods. Comprehensive simulations on a test distribution network are used to show that the suggested method is effective. The system's performance can be optimized in terms of grid stability, efficiency, and reliability, according to the results. By stressing the significance of employing a hybrid MC-GA technique to meet realistic load circumstances, this research advances optimal DG and EV solutions.

Keywords: Distributed Generators (DGs), Optimal Integration, Electric Vehicles (EVs), Realistic Load Models (RLMs), Location and size.

I. INTRODUCTION

The integration of DGs and EVs into the power grid is driven by several factors that aim to enhance the efficiency, reliability, and sustainability of the electricity system. Both DGs and EVs are important components of the modern energy landscape, and their integration brings about numerous benefits and challenges. The conventional centralized power generation paradigm is shifting towards a decentralized model, where DGs such as solar photovoltaic (PV) systems, wind turbines, and micro-turbines are seamlessly incorporated into the distribution network. Simultaneously, the proliferation of EVs, motivated by the imperative to reduce carbon emissions and dependence on fossil fuels, is reshaping the way energy is consumed and stored. The integration of DGs and EVs brings forth a complex set of challenges. These include uncertainty associated with variable renewable generation, diverse EV charging patterns, and the need for effective energy management strategies to ensure grid stability and minimize environmental impact. Consequently, optimizing the integration of DGs and EVs becomes paramount to achieving a resilient and sustainable energy landscape. Traditional optimization techniques may fall short due to the inherent complexity and non-linearity of these problems, coupled with the necessity to consider realistic load behaviours. To address these challenges, this paper proposes a novel approach that combines the strengths of the Monte Carlo (MC) simulation method and Genetic Algorithm (GA) optimization technique. This hybrid MC-GA approach is tailored to address the uncertainties inherent in DG and EV integration by employing probabilistic analysis and evolutionary optimization. In particular, the proposed approach places a strong emphasis on the use of realistic load models, recognizing that accurate load modelling is essential to capture the true operational conditions of the distribution network. The subsequent sections of this paper elaborate on the methodology, incorporating the modelling of DG and EV integration, including various load models. The hybrid MC-GA technique is then detailed, showcasing its ability to effectively address multi-objective optimization problems in the context of DG and EV integration. A comprehensive case study on a test distribution network substantiates the proposed approach's

¹ *Department of Electrical Engineering, Integral University, Lucknow, Uttar Pradesh-226026 (India)

² Department of Electrical Engineering, Integral University, Lucknow, Uttar Pradesh-226026 (India)

³ Department of Electrical Engineering, Kamla Nehru Institute of Technology, Sultanpur, Uttar Pradesh-228118 (India)

effectiveness in enhancing system performance, reliability, and efficiency. In this research contributes to the growing body of knowledge by presenting a holistic solution for the optimal integration of DGs and EVs.

A distribution estimate technique based on statistics (Bayesian estimate) is presented for both static and dynamic load models by Li et al. [1]. Singh et al. [2] suggested utilizing GA to minimize the system's overall real power loss in order to improve the voltage profile in distribution power networks using DG integrated with D-STATCOM and various load models, including constant power, constant current, constant impedance, composite, and reference load models. For islanded microgrids with PEVs, Abdelalziz et al. [3] developed a unique approach for a multistage centralised control technique. Interface In V2G systems, a bidirectional inductive power for EVs was described. by Madawala et al. [4]. The multiobjective optimization to plan DGs using load models was recommended by Singh et al. [5]. An ideal scheduling of home appliances using day-ahead pricing and demand response that shapes load algorithms was provided by Paterakis et al. [6]. Employing a multi-objective PSO with AA to position and scale DG on distribution systems: a review was recommended by Pooja and Sameena [7]. Jorge et al. [8] suggested distributed generating operating mode-aware restoring several faults in a service. It was suggested by Khursheed et al. [9] to tune the controllers for a boost converter that interfaces a battery source to the BTS load of a telecommunication site. Ramesh et al. [10] suggested Optimal Integration of DGs in Distribution Networks using Realistic Load Models with Hybrid MC-GA Technique. Plug-in electric car with distributed solar voltage support: theory and application was presented by Foster et al. [11]. Cooperative control of a wind turbine and an electric car for main frequency regulation of a microgrid was recommended by Fakhari et al. [12]. Vimlesh et al. [13] presented a hybrid GA-MCS optimization for DG and DVR planning in distribution systems with ZIP-LMs. It was recommended that Payasi et al. [14] use the DG planning strategy, which uses both conventional and unconventional energy sources to generate electricity. One such source is DG, which delivers high momentum and has a major influence on dispersed networks. Khan et al. [15] suggested FACTS controller scheme deployment for improved power system security in an Indian context. According to Siddiqui et al. [16], PIDF controller tuning in a parallel control structure is recommended for process integration that includes time delay and inverse response characteristic. A review was suggested for performance-based study of solar PV emulators, Shahabuddin et al. [17]. An analysis of how plug-in EVs affect distribution networks was provided by Fernández et al. [18]. An ideal scheduling of home appliances using day-ahead pricing and demand response that shapes load algorithms was provided by Paterakis et al. [19]. A review of load modeling and its identification methods is provided by Arif et al. [20]. In order to improve system performances, Bokhari et al. [21] address the coefficient of ZIP-LMs for DGs planning with load models in distribution systems. Singh and associates [22] GA-based optimization is recommended for the integration of PHEVs, STATCOM, and DGs in distribution networks. GA is used to solve an ODGP that takes dispersed loads, constant power concentrated loads, and variable power concentrated load models into consideration, as explained by Shukla et al. [23]. For the purpose of improving system performance, Khodayar et al. [24] proposed coordination of SCUC's hourly EV operation with varying wind output. Gagari et al. [25] improved SMO-based DG placement in radial distribution networks was suggested for improving voltage security. Sulaiman et al. [26] employing the firefly method, the distribution system optimum DG size and allocation was provided in order to increase system performance. Singh et al. [27] focus was on installing EV charging stations powered by solar PV batteries and diesel engines. A safe charging system for EVs with smart communities on energy blockchain was proposed by Su et al. [28]. From the perspective of the main substation's minimum total MVA intake, a GA was proposed for the effect evaluation of strategically located distributed generation (DGs) with different load models in order to optimize system power performances, including RPL and REPL, environment greenhouse gases, and voltage profile, as indicated by Singh et al. [29]. Singh and colleagues [30] developed a GA-based multiobjective optimization approach for distributed generation planning in distribution power systems with DLMS. Joint optimization was proposed by Zhang et al. [31] to reduce power loss in distribution systems. A hybrid GA-MCS optimization was presented by Vimlesh et al. [32] for DG, DVR, and DSTATCOM planning in distribution systems with ZIP-LMs. A multi-objective GA is employed as an optimization method for these problems. Because GA may simultaneously develop several multi-objective solutions, it has lately been recognized as being especially well-suited for multi-objective optimization problems. This approach is utilized in place of an optimization algorithm [33]-[34]. In order to improve system performances, Patel et al. [35] addressed a suggested approach for various forms of DGs planning in the distribution system, such as GA-based optimization. Singh and Goswami [36] developed multi-objective optimization of distributed generation planning utilizing impact indices and trade-off approach, as well as the best distribution of distributed generation units (DGs) based on nodal pricing

for profit, loss reduction, and voltage enhancement, including the issue of voltage rise. [37]-[38]. A survey on the evaluation of the effects of DG and FACTS controllers in power systems was proposed by Singh et al. [39]. For the purpose of improving system performance, Sanjaka and Ali [40] proposed a categorization and review of control mechanisms for PHEVs.

In these circumstances, distribution network systems are facing ever-increasing challenges over time. The penetration of EVs and DGs is growing more quickly. More attention should be paid to DG units that employ intermittent sustainable energy sources, such as wind and solar electricity, in between them. For the distribution network system to operate effectively and efficiently, these technological advancements will bring both opportunities and problems. Overloading on the distribution network will decrease with widespread DG and EV integration. There are a few drawbacks that might impair the DG System's ability to function in terms of security and distribution system power quality, and connecting DGs is not always beneficial. By lowering or delaying financing for transmission line building, lowering resistance-related loss (ohmic losses), and making minimal investments in transformers, DG's potential benefits may also be maintained. These methods will undoubtedly turn out to be environmentally beneficial as well.

The following elements are taken into account while designing DGs, EVs, and their coordination: i) size; ii) geography and place; iii) types/models; and iv) scope of coordination. Since there were fewer RAM processors available twenty years ago, researchers used two of the aforementioned characteristics for simulation at a time, according to my review of the literature. However, now that there are more RAM processors available, researchers are using three parameters at a time. All of the above listed factors will be considered in future DGs with EVs analyses. This research critically examines the current modeling and optimization approaches for input-output and planning parameter connections.

A thorough analysis of these methods reveals a crucial issue with optimization during DG and EV installation. This paper uses realistic load models and the MC-GA technique in distributed networks systems to analyze the planning for DGs, EVs, and their coordination. The distribution system is dealing with new grid security challenges as a result of the rise in high power consumption loads like DGs and EVs. The increasing use of DG and EVs is another factor contributing to these security concerns.

The remaining portions are set up as follows: *Section 2* discusses the planning of DGs mathematical modelling of the present work. *Section 3* discussed hybrid MC-GA implementation. *Section 4* discusses the simulation and results. Conclusions along with possible future scope of the Article's manifest themselves in *Section 5*.

II. MATHEMATICAL FORMULATION OF DG AND EV PLANNING

RLMs [Constant Impedance Current and Power (ZIP) +Induction Motor (IM)] and different types of DGs and EV modelling are presented in sub-sections *A*, *B* and *C*.

A. RLMs (ZIP+IM)

Recent work has focused on combining the dynamic and static load models. When compared to separate load models with transient disturbances, it was shown that composite models can produce more accurate results. The most widely used model in the US industry for dynamic research is the composite load model, along with RLMs made up of a ZIP code and an induction motor, according to the study in [33]. Numerous composite load models, including ZIP+IM, were taken into consideration in [20]. The study came to the conclusion that loads with a variety of compositions, circumstances, and locations may be modelled using the ZIP+IM structure. Fig.1 depicts the analogous circuit of the ZIP+IM model.

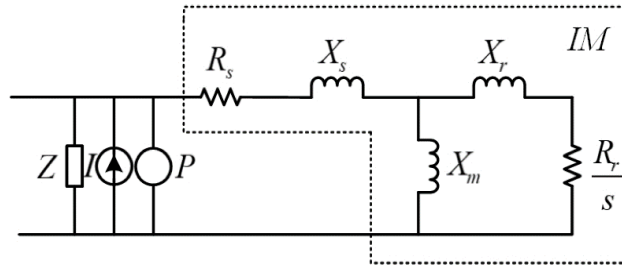

Fig 1. Equivalent circuit of RLMs (ZIP+IM) model

Table 1: RLMs (ZIP+IM) and their behaviours [1-2, 20, 35]

RLMs	Appliances(ZIP+IM)	Features/behaviours	Comparisons
RLM1	Incandescent light with IM	Resistive loads consume electrical power in such a manner that the current wave remains in phase with the voltage wave. So p.f. is unity but an inductive loads has lagging p.f.	Dynamic resistive and inductive load
RLM2	Refrigerator with IM	An inductive load causes the current wave to lag the voltage wave. Hence p.f. of an inductive load is lagging.	Highly inductive load
RLM3	Microwave with IM	An inductive load causes the current wave to lag the voltage wave. Hence p.f. of an inductive load is lagging.	Highly inductive load as compared to RLM2
RLM4	Computer with IM	A capacitive load causes the current wave to lead the voltage wave and for inductive load behave opposite to capacitive load.	Low capacitive and inductive load
RLM5	Advanced washing machine with IM	An inductive load causes the current wave to lag the voltage wave. Hence p.f. of an inductive load is lagging.	Highly inductive load as compared to RLM2 and RLM3

Table 2: Active and reactive power coefficients for RLMs (actual cut-off voltages) [13, 32]

RLMs	Equipments	V_0	P_0	P			Q			
				$\frac{Q_0}{Z_p}$	I_p	$\frac{P_p}{Z_q}$	I_q	P_q		
RLM1	Incandescent light with IM	120	3.38	5.85	0.69	0.92	-0.61	1.84	-0.91	0.07
RLM2	Refrigerator with IM	120	119.55	52.47	5.03	-8.48	4.45	17.4 4	- 28.6 2	12.18
RLM3	Microwave with IM	120	1365.5 3	451.0 2	-0.27	1.16	0.11	15.6 4	- 27.7 4	13.1
RLM4	Computer with IM	120	253	44	0.19	-0.45	1.26	10.1 8	- 18.0 1	8.83
RLM5	Advanced washing machine with IM	120	855	221	0.92	0.07	0.01	0.91	-0.02	0.11

These many types of RLMs are available and might be used in DGs and DGs with EV planning to improve the SPF profile and power system performance metrics including actual power and reactive power losses.

B. DG Modelling [14]

In general, the DGs are categorized as supporting both delivered/absorbed and real reactive power.

- DG1 system only accepts real power with a power factor of one. Examples include solar panels, photovoltaics, biogas, etc.
- DG2 system supports both real and reactive power, based on leading power factor of 0.80 to 0.99. Some examples are Tidal, wind, geothermal, wave, etc.
- DG3 system supports Reactive power based on power factor of 0.00. Few examples are, inductor bank, synchronous condenser, capacitors bank etc.
- DG4 having lag power factors ranging from 0.80 to 0.99, It provides the system with active power. and depending on operating conditions, it draws reactive power from the system and either absorbs it or gives it. For instance, wind-powered induction generators that are double fed.

The details these various kinds of DGs are mentioned in Table 3.

Table 3: Different DGs and samples of each

PF ranges	DG model	Power injection capability	Example
Unity	Type 1	Active power only	Fuel cells, microturbines, biogases, and solar photovoltaics <i>etc.</i>
0.80 < PF < 0.99, leading	Type 2	Both reactive and active power	Synchronous machines, co-generation, gas turbines, and tidal, geothermal, wind <i>etc.</i>
Zero	Type 3	Reactive Power only	Facts controllers, banks of capacitors, inductors, and synchronous condensers, among other components <i>etc.</i>
0.80 < PF < 0.99, lagging	Type 4	Both active and reactive power are used.	Wind power doubly fed induction generators <i>etc.</i>

C. EV Modelling [14]

Electric Vehicles (EVs) integration refers to the incorporation of electric vehicles into the existing transportation and energy systems. This integration involves not only the adoption of electric cars but also the development of supporting infrastructure, charging networks, and grid management strategies. The integration of EVs has gained prominence due to its potential to reduce greenhouse gas emissions, decrease dependence on fossil fuels, and enhance grid flexibility through vehicle-to-grid (V2G) technology. There are four quadrants operation of EVs function .Table 4 addresses the real and reactive power figures for various EVs.

Table 4: Real power & reactive power of four different types of quadrant operation of EVs [35]

EVs	Real power	Reactive power
BEVs	P_{BEVs}	-
PHEVs	P_{PHEVs}	Q_{PHEVs}
Ex-PHEVs	$P_{Ex-PHEVs}$	$Q_{Ex-PHEVs}$
FCEVs	P_{FCEVs}	-

In case of main substation, Total MVA intake without having DGs and EVs is provided by equ. (1).

$$S_{WODG,EV} = \sqrt{P_G^2 + Q_G^2} \tag{1}$$

In case of main substation, Total MVA intake with different types of DGs (DG1, DG2, DG3 and DG4 respectively) are given in equ. (2) - (5):

$$S_{WDG1} = \sqrt{(P_G + P_{DG1})^2 + Q_G^2} \quad (2)$$

$$S_{WDG2} = \sqrt{(P_G + P_{DG2})^2 + (Q_G + Q_{DG2})^2} \quad (3)$$

$$S_{WDG3} = \sqrt{P_G^2 + (Q_G + Q_{DG3})^2} \quad (4)$$

$$S_{WDG4} = \sqrt{(P_G + P_{DG4})^2 + (Q_G \pm Q_{DG4})^2} \quad (5)$$

In case of main substation, Total MVA intake with integration of different types of DGs (DG1, DG2, DG3 and DG4 respectively) and EVs in distribution system are given in equ. (6) - (9):

$$S_{WDG1+EVs} = \sqrt{(P_G + P_{DG1} + P_{EVs})^2 + (Q_G \pm Q_{EVs})^2} \quad (6)$$

$$S_{WDG2+EVs} = \sqrt{(P_G + P_{DG2} + P_{EVs})^2 + (Q_G + Q_{DG2} \pm Q_{EVs})^2} \quad (7)$$

$$S_{WDG3+EVs} = \sqrt{(P_G + P_{EVs})^2 + (Q_G + Q_{DG3} \pm Q_{EVs})^2} \quad (8)$$

$$S_{WDG4+EVs} = \sqrt{(P_G + P_{DG4} + P_{EVs})^2 + (Q_G \pm Q_{DG4} \pm Q_{EVs})^2} \quad (9)$$

The SPF without having DGs and EVs is provided by equ. (10).

$$SPF_{WODG,EVs} = \frac{P_G}{\sqrt{P_G^2 + Q_G^2}} \quad (10)$$

The SPF with different types of DGs (DG1, DG2, DG3 and DG4 respectively) are given in equ. (11) - (14):

$$SPF_{WDG1_RLMi} = \frac{P_G + P_{DG1_RLMi}}{\sqrt{(P_G + P_{DG1_RLMi})^2 + Q_G^2}} \quad (11)$$

$$SPF_{WDG2_RLMi} = \frac{P_G + P_{DG2_RLMi}}{\sqrt{(P_G + P_{DG2_RLMi})^2 + (Q_G + Q_{DG2_RLMi})^2}} \quad (12)$$

$$SPF_{WDG3_RLMi} = \frac{P_G}{\sqrt{P_G^2 + (Q_G + Q_{DG3_RLMi})^2}} \quad (13)$$

$$SPF_{WDG4_RLMi} = \frac{P_G + P_{DG4_RLMi}}{\sqrt{(P_G + P_{DG4_RLMi})^2 + (Q_G \pm Q_{DG4_RLMi})^2}} \quad (14)$$

The SPF with integration of different types of DGs (DG1, DG2, DG3 and DG4 respectively) and EVs in distribution system are given in equ. (15) - (18):

$$SPF_{WDG1+EVs_RLMi} = \frac{P_G + P_{DG1_RLMi} + P_{EVs_RLMi}}{\sqrt{(P_G + P_{DG1_RLMi} + P_{EVs_RLMi})^2 + (Q_G \pm Q_{EVs_RLMi})^2}} \quad (15)$$

$$SPF_{WDG2+EVs_RLMi} = \frac{P_G + P_{DG2_RLMi} + P_{EVs_RLMi}}{\sqrt{(P_G + P_{DG2_RLMi} + P_{EVs_RLMi})^2 + (Q_G + Q_{DG2_RLMi} \pm Q_{EVs_RLMi})^2}} \quad (16)$$

$$SPF_{WDG3+EVsRLMi} = \frac{P_G + P_{EVsRLMi}}{\sqrt{(P_G + P_{EVsRLMi})^2 + (Q_G + Q_{DG3RLMi} \pm Q_{EVsRLMi})^2}} \quad (17)$$

$$SPF_{WDG4+EVsRLMi} = \frac{P_G + P_{DG4RLMi} + P_{EVsRLMi}}{\sqrt{(P_G + P_{DG4RLMi} + P_{EVsRLMi})^2 + (Q_G \pm Q_{DG4RLMi} \pm Q_{EVsRLMi})^2}} \quad (18)$$

Where P_G is active power (in MW), Q_G is reactive power (in MVAR), P_{DGRLMi} is the real power delivered by DG (in MW) and Q_{DGRLMi} is the reactive power delivered by DG (in MVAR) with RLMs. Where $i = 1, 2, 3, 4$ & 5 for RLMs (RLM1, RLM2, RLM3, RLM4 & RLM5).

Objective function related to Real power loss minimization, represented by PL in the system, is focused upon minimizing the loss of real power. Mathematical representation using equation is mentioned below (19).

$$P_{Loss} = \frac{P_{nj_bus}^2 + Q_{nj_bus}^2}{|V_{n_bus}|^2} r_{nj_bus} \text{ for } n, j \in N \quad (19)$$

The PL depends on every system bus voltage (V_{i_bus}) , line resistances (r_{ij_bus}) .

Objective function related to Reactive power loss minimization represented by QL in the system, is focused upon minimizing the loss of total reactive power. Mathematical representation using equation is mentioned below (20).

$$Q_{Loss} = \frac{P_{nj_bus}^2 + Q_{nj_bus}^2}{|V_{n_bus}|^2} x_{nj_bus} \text{ for } n, j \in N \quad (20)$$

The QL depends on every system bus voltage (V_{n_bus}) , line resistances (x_{nj_bus}) , and the voltage profile mostly determines the overall loss.

III. HYBRID MC-GA IMPLEMENTATION [13 – 14]

An outline of the hybrid MC-GA technique's uses and applications.

Combining two optimization techniques—Genetic Algorithms (GA) and Monte Carlo (MC) simulation is known as the hybrid MC-GA strategy. Particularly in engineering, finance, and other scientific domains, this method is employed to resolve intricate optimization issues involving uncertainties and numerous variables.

Genetic Algorithms (GA): They involve the evolution of a population of potential solutions through generations. Solutions are encoded as "chromosomes," and operations like selection, crossover, and mutation are applied to mimic the evolutionary process and improve the quality of solutions over time. The flowchart for hybrid MC-GA for integration of DG with EV planning and SPF improvement with RLMs from the minimization of the real and reactive power losses viewpoints is shown in Fig. 2.

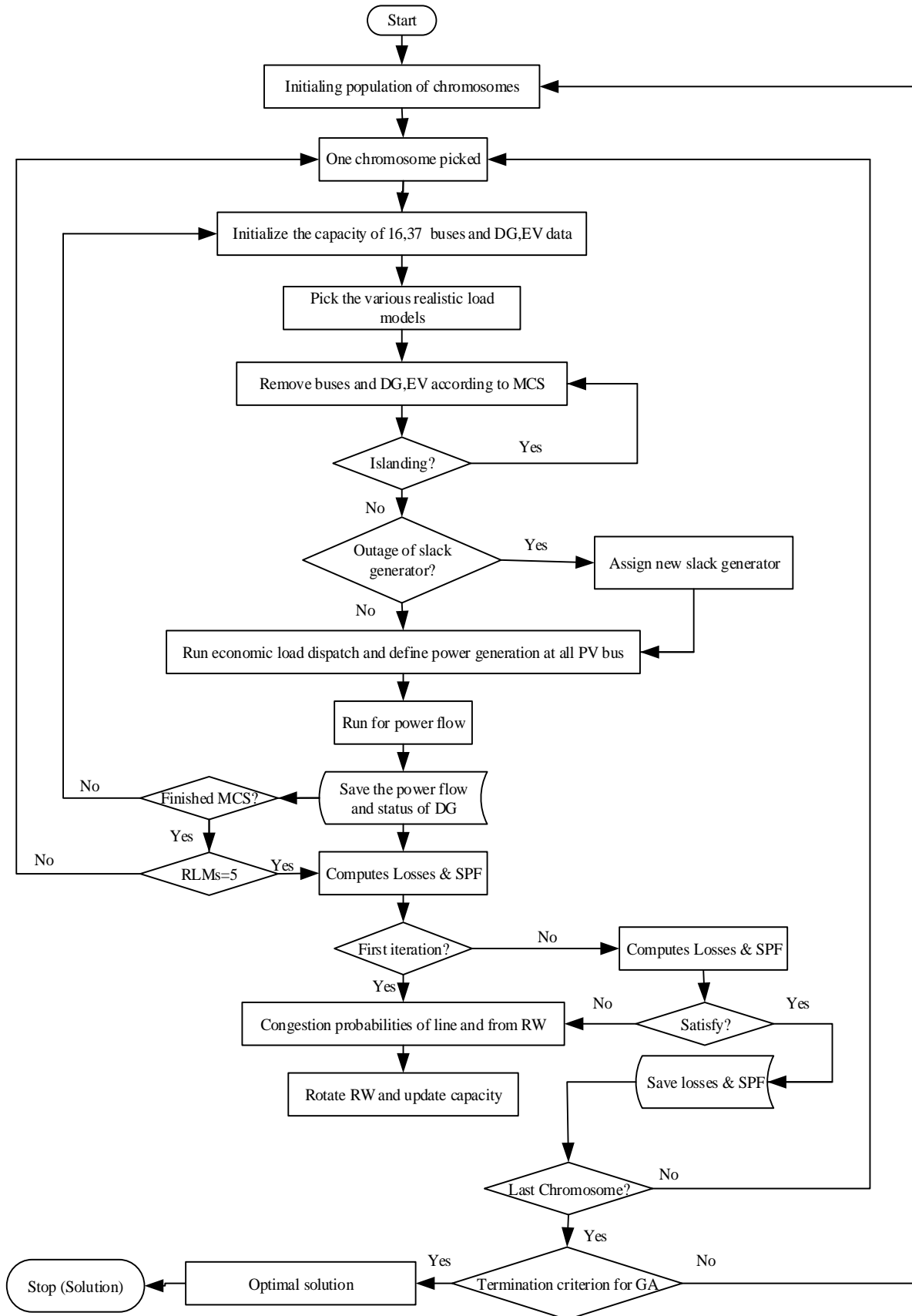

Fig. 2. DG's recommended optimization flow chart with EV planning and SPF enhancement using RLMs.

Hybrid MC-GA Technique: The hybrid MC-GA approach addresses optimization problems with unknown parameters by combining the advantages of GA optimization with MC simulation. This is how it operates:

Initialization: A population of potential solutions (chromosomes) is generated.

Evaluation: Every response is assessed using MC simulation over a range of scenarios, considering the uncertainty in variables.

Selection: GA operators (selection, crossover, and mutation) are applied to the solutions. Solutions with better performance, as determined by the MC simulation, have a higher probability of being selected for crossover and mutation.

New Population: A new population of solutions is created through the application of GA operators.

Iteration: Steps 2-4 are repeated for multiple generations, with the aim of improving the quality of solutions by exploring various combinations of variables and scenarios.

Applicability: Numerous optimization problems, particularly those involving uncertainty and several variables, might benefit from the hybrid MC-GA approach. Among the fields in which it can be used are:

Engineering Design: Optimal design of complex systems considering uncertain material properties, loads, and operating conditions.

Financial Portfolio Optimization: Optimizing investment portfolios considering uncertain market conditions and asset performance.

Supply Chain Management: Optimizing supply chain operations while accounting for uncertain demand and supply disruptions.

Environmental Management: Finding optimal solutions for environmental management problems, considering uncertainties in pollution levels and resource availability.

Energy System Design: Designing hybrid energy systems that incorporate renewable and conventional energy sources under uncertain weather conditions and energy demand.

An effective method for resolving optimization issues containing uncertainty is the hybrid MC-GA methodology. This method makes it possible to find reliable solutions that function well in a variety of situations by fusing the evolutionary search skills of Genetic Algorithms with the probabilistic evaluation capabilities of Monte Carlo simulation. It is applicable in a wide range of fields where decision-making is heavily influenced by uncertainty.

IV. SIMULATION RESULTS AND DISCUSSION

The recommended strategy for penetration of several DGs and EVs planned with distinct RLMs has been put into practice on IEEE-16 and 37 bus distribution systems. The software runs on a 2.63 GHz Pentium core i7 processor with 32 GB of RAM and was developed using the MATLAB 2019b programming language. Figures 3, 4, and Table 5, 6 display the data related to the IEEE-16 bus (17-node) and IEEE-37 bus (38-node) distribution test systems, respectively. The numbers in the research correspond to a hypothetical 37-bus, 12.66-KV system [31]. The overall substation loads for the base design are 5084.26 kW and 2547.32 kVAr. The system is lossy and has poor compensation, with a total loss of about 8% of the total load. Since a discernible decrease in loss is expected, the lossy system is selected. The 16-bus test system is a subsystem of the proposed 37-bus test system [32]. For the test systems mentioned above, the fundamental values used are 23 kV and 100 MVA. The complete power flow solution for the distribution networks with 16 and 37 buses can be obtained using the following technique. First, a DG size is assessed between 0-0.63 p.u., which is a reasonable range. A condition with the maximum possible intended DG value is represented by a DG of 0.72 p.u., whereas a system with no DG is represented by a DG of 0.0 p.u.

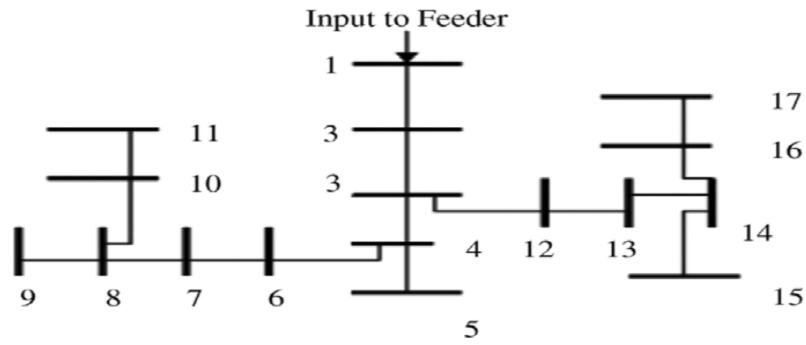

Fig. 3. IEEE 16 Bus (17 Node) distribution test system

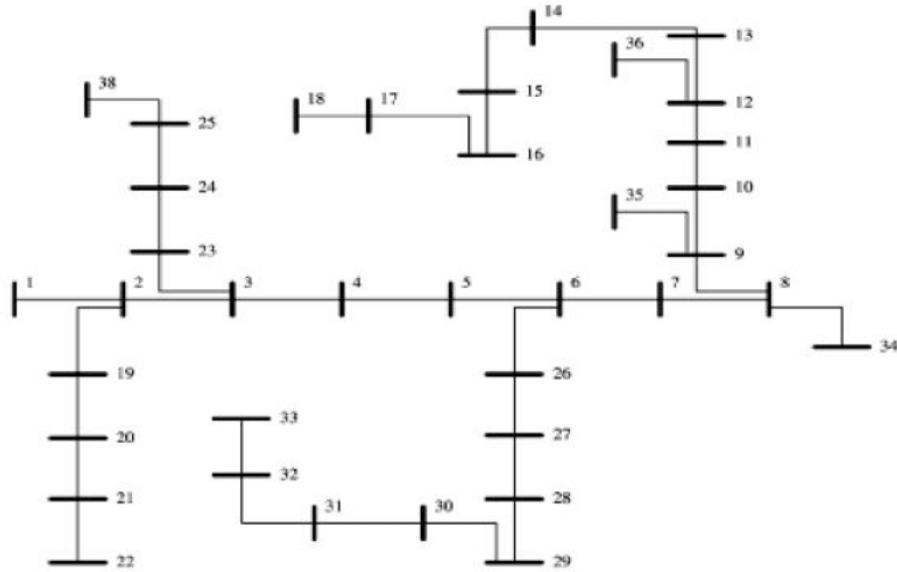

Fig. 4. IEEE 37 Bus (38 Node) distribution test system

Table 5: Line parameter and load data for IEEE-16 bus distribution test system [10]

From	To	Line impedance (p.u.)		Line no.	Ratings (p.u.)	Load on the node (p. u.)	
		R	X			L	P
1	2	0.000574	0.000293	1	2.8	0.1	0.06
2	3	0.00307	0.001564	6	2.5	0.09	0.04
3	4	0.002279	0.001161	11	2.1	0.12	0.08
4	5	0.002373	0.001209	12	0.84	0.06	0.03
4	6	0.0051	0.004402	13	1.5	0.06	0.02
6	7	0.001166	0.003853	22	1.3	0.20	0.10
7	8	0.00443	0.001464	23	1.04	0.20	0.10
8	9	0.006413	0.004608	25	0.48	0.06	0.02
8	10	0.006501	0.004608	27	1.5	0.06	0.02
10	11	0.001224	0.000405	28	0.18	0.045	0.03
3	12	0.002331	0.000771	29	0.64	0.06	0.035
12	13	0.009141	0.007192	31	0.55	0.06	0.035

13	14	0.003372	0.004439	32	0.45	0.12	0.08
14	15	0.00368	0.003275	33	0.12	0.06	0.01
14	16	0.004647	0.003394	34	0.15	0.06	0.02
16	17	0.008026	0.010716	35	0.07	0.06	0.02

P = Real power MW load, Q = Reactive power MVA_r load

Table 6: Line parameter and load data for IEEE-37 bus distribution test system [2]

From	To	Line impedance (p.u.)		Line no.	Ratings (p.u.)	Load on the node (p. u.)	
		R	X			L	P
1	2	0.000574	0.000293	1	4.60	0.1	0.06
2	3	0.00307	0.001564	6	0.50	0.09	0.04
3	4	0.002279	0.001161	11	0.50	0.12	0.08
4	5	0.002373	0.001209	12	0.21	0.06	0.03
4	6	0.0051	0.004402	13	0.11	0.06	0.02
6	7	0.001166	0.003853	22	4.10	0.20	0.10
7	8	0.00443	0.001464	23	1.05	0.20	0.10
8	9	0.006413	0.004608	25	1.05	0.06	0.02
8	10	0.006501	0.004608	27	0.50	0.06	0.02
10	11	0.001224	0.000405	28	0.10	0.045	0.03
3	12	0.002331	0.000771	29	2.90	0.06	0.035
12	13	0.009141	0.007192	31	2.90	0.06	0.035
13	14	0.003372	0.004439	32	2.90	0.12	0.08
14	15	0.00368	0.003275	33	1.50	0.06	0.01
14	16	0.004647	0.003394	34	1.50	0.06	0.02
16	17	0.008026	0.010716	35	1.50	0.06	0.02
17	18	0.004558	0.003574	36	1.50	0.09	0.04
2	19	0.001021	0.000974	2	1.50	0.09	0.04
19	20	0.009366	0.00844	3	0.50	0.09	0.04
20	21	0.00255	0.002979	4	0.50	0.09	0.04
21	22	0.004414	0.005836	5	0.10	0.09	0.04
3	23	0.002809	0.00192	7	1.50	0.09	0.04
23	24	0.005592	0.004415	8	1.05	0.42	0.2
24	25	0.005579	0.004366	9	0.50	0.42	0.2
6	26	0.001264	0.000644	14	1.05	0.06	0.025
26	27	0.00177	0.000901	15	0.50	0.06	0.025
27	28	0.006594	0.005814	16	1.05	0.06	0.02

28	29	0.005007	0.004362	17	1.05	0.12	0.07
29	30	0.00316	0.00161	18	1.05	0.2	0.6
30	31	0.006067	0.005996	19	0.50	0.15	0.07
31	32	0.001933	0.002253	2	0.50	0.21	0.1
32	33	0.002123	0.003301	21	0.45	0.06	0.04
8	34	0.012453	0.012453	24	0.30	0	0
9	35	0.012453	0.012453	26	0.25	0	0
12	36	0.012453	0.012453	30	0.25	0	0
18	37	0.003113	0.003113	37	0.10	0	0
25	38	0.00313	0.003113	10	0.50	0	0

P = Real power MW load, Q = Reactive power MVAr load

Table 7: Penetration of different types of DGs with EV and SPF profile planning in 16-Bus system with RLMs

(ZIP+IM)

RLMs (ZIP+IM)	DG with EV	DG Type	DG P.F.	Optimal DG Size $S_{DG(p.u.)}$	Optimal EV Size $S_{EV(p.u.)}$	DG Loc.	EV					SPF Profile
							Loc.	P_L (p.u.)	Q_L (p.u.)	P_G (p.u.)	Q_G (p.u.)	
RLM1	WODG&EV	-	-	-	-	-	-	1.5213	1.3302	0.4121	0.4003	0.7473
	WDG	DG1	1.00	0.1404	-	7	-	1.2672	1.1300	0.4111	0.4035	0.7814
		DG2	0.85 ld	0.1414	-	8	-	1.2100	1.1102	0.4170	0.4037	0.8032
		DG3	0.00	0.1201	-	8	-	1.3848	1.3110	0.4037	0.4091	0.7463
		DG4	0.85 lg	0.1230	-	8	-	1.3605	1.2001	0.4101	0.4101	0.7541
	WDG & EV	DG1+EV	1.00	0.1404	-0.10	7	5	1.1012	1.0004	0.4116	0.4007	0.8820
		DG2+EV	0.85 ld	0.1414	-0.10	8	5	1.0022	0.9502	0.4130	0.4010	0.9621
		DG3+EV	0.00	0.1201	-0.10	8	7	1.2301	1.1703	0.4012	0.4048	0.8320
DG4+EV		0.85 lg	0.1230	-0.10	8	10	1.1803	1.0405	0.4103	0.4093	0.8523	
RLM2	WODG&EV	-	-	-	-	-	-	1.5213	1.3302	0.4121	0.4003	0.7473
	WDG	DG1	1.00	0.1463	-	7	-	1.1906	1.1200	0.4122	0.4035	0.7901
		DG2	0.85 ld	0.1475	-	7	-	1.1700	1.1120	0.4133	0.4037	0.8041
		DG3	0.00	0.1107	-	8	-	1.4401	1.2329	0.4101	0.4089	0.7438
		DG4	0.85 lg	0.1132	-	9	-	1.3812	1.2003	0.4099	0.4100	0.7600
	WDG & EV	DG1+EV	1.00	0.1463	-0.12	7	5	1.1001	1.0002	0.4118	0.4030	0.8901
		DG2+EV	0.85 ld	0.1475	-0.12	7	8	1.0210	0.9602	0.4138	0.4030	0.9681
		DG3+EV	0.00	0.1107	-0.12	8	7	1.2407	1.1307	0.4100	0.4050	0.8310
DG4+EV		0.85 lg	0.1132	-0.12	9	10	1.1905	1.1022	0.4099	0.4121	0.8551	
RLM3	WODG&EV	-	-	-	-	-	-	1.5213	1.3302	0.4121	0.4003	0.7473
	WDG	DG1	1.00	0.1507	-	8	-	1.2908	1.1103	0.4112	0.4001	0.8103
		DG2	0.85 ld	0.1497	-	8	-	1.2505	1.1005	0.4133	0.4030	0.8120

	DG3	0.00	0.1170	-	7	-	1.4530	1.2570	0.4113	0.4017	0.7662	
	DG4	0.85 lg	0.1228	-	5	-	1.4217	1.2097	0.4137	0.4003	0.7670	
RLM4	WDG & EV	DG1+EV	1.00	0.1507	-0.10	8	5	1.1023	1.0001	0.4107	0.4000	0.9003
		DG2+EV	0.85 ld	0.1497	-0.10	8	5	1.0201	0.9503	0.4127	0.4026	0.9703
		DG3+EV	0.00	0.1170	-0.10	7	8	1.2409	1.1305	0.4110	0.4011	0.8401
		DG4+EV	0.85 lg	0.1228	-0.10	5	7	1.1890	1.1012	0.4130	0.4001	0.8703
	WODG&EV	-	-	-	-	-	-	1.5213	1.3302	0.4121	0.4003	0.7473
	WDG	DG1	1.00	0.1402	-	7	-	1.2103	1.1362	0.4112	0.4001	0.8120
		DG2	0.85 ld	0.1419	-	8	-	1.1313	1.0990	0.4114	0.4103	0.8179
		DG3	0.00	0.1210	-	8	-	1.4204	1.2249	0.4175	0.4101	0.7513
RLM5		DG4	0.85 lg	0.1237	-	7	-	1.3902	1.1670	0.4118	0.4002	0.7510
	WDG & EV	DG1+EV	1.00	0.1402	-0.13	7	5	1.1001	1.0001	0.4113	0.4003	0.9006
		DG2+EV	0.85 ld	0.1419	-0.13	8	7	1.0150	0.9401	0.4115	0.4105	0.9706
		DG3+EV	0.00	0.1210	-0.13	8	5	1.2302	1.1301	0.4174	0.4100	0.8408
		DG4+EV	0.85 lg	0.1237	-0.13	7	10	1.1705	1.1009	0.4119	0.4003	0.8709
	WODG&EV	-	-	-	-	-	-	1.5213	1.3302	0.4121	0.4003	0.7473
	WDG	DG1	1.00	0.1465	-	8	-	1.1820	1.1226	0.4112	0.4002	0.8183
		DG2	0.85 ld	0.1472	-	7	-	1.1332	1.1035	0.4102	0.4020	0.8193
	DG3	0.00	0.1103	-	9	-	1.4001	1.3011	0.4124	0.4101	0.7512	
	DG4	0.85 lg	0.1125	-	7	-	1.3222	1.1532	0.4103	0.4003	0.7563	
	WDG & EV	DG1+EV	1.00	0.1465	-0.15	8	7	1.1002	1.0003	0.4113	0.4001	0.9005
		DG2+EV	0.85 ld	0.1472	-0.15	7	5	1.0150	0.9402	0.4103	0.4018	0.9707
		DG3+EV	0.00	0.1103	-0.15	9	5	1.2302	1.1300	0.4126	0.4103	0.8406
		DG4+EV	0.85 lg	0.1125	-0.15	7	10	1.1707	1.1009	0.4101	0.4106	0.8707

The variation of optimal EV size for RLMs in distribution systems are given in Fig.5. The optimal size of EV (0.15 p.u.) is maximum in RLM5 and (0.10 p.u.) minimum in RLM1 & RLM3 load model in comparison to other load model for all type of DGs (like DG1, DG2, DG3 & DG4).

Fig.6. Show the optimal EV location and Fig.7. display how the true power loss profile changes for RLMs both with and without DGs & EV. Comparing the RLM4 and RLM2 load model with DG1+EV, the real power loss decrease (1.1001 p.u.) is noteworthy when compared to other LMs. Therefore, bus 5 is the best place for DG1+EV to be located. When DG2+EV is used in the RLM1 load model, the real power loss decrease (1.0022 p.u.) is also noteworthy. Therefore, bus 5 is the best places for DG2+EV to be. In the RLM1 load model, the real power loss reduction of 1.2301 p.u. using DG3+EV is noteworthy. Hence, bus 7 is the best place for DG3+EV to be. With RLM4 load conditions, the actual power loss (1.1705 p.u.) is also at a minimum for DG4+EV, and bus 7 with 0.85 lag power factor is the best bus site for DG4+EV deployment. Based on the analysis, bus 5 with DG2+EV for real power loss reduction is the best position in the RLM1 load model condition because DG2+EV provides the system with both reactive and real power at leading power factors of 0.80 to 0.99. The best real power loss reduction with RLMs are achieved in case of DG2+EV whereas the poorest real power loss reduction with RLMs are achieved in case DG3+EV. The descending order of real power loss reduction with RLMs are as follows: DG2+EV > DG1+EV > DG4+EV > DG3+EV

The reactive power loss profile variation for RLMs with and without DGs+EV is displayed in Fig. 8. In the RLM3 and RLM4 load model, DG1+EV significantly reduces reactive power loss (1.0001 p.u.) as compared to other LMs. With DG2+EV having a 0.85 lead power factor in the RLM4 load model, the reduction in reactive power loss (0.9401 p.u.) is also noteworthy. In the RLM5 load model, the reduction in reactive power loss (1.1300 p.u.) using DG3+EV is noteworthy. For DG4+EV, the minimal reactive power loss (1.0405 p.u.) under RLM1 load conditions corresponds to a 0.85 lag power factor. When using RLMs, DG2+EV achieves the best reduction in reactive power loss, whereas DG3+EV achieves the lowest decrease in reactive power loss. The descending order of reactive power loss reduction with RLMs are as follows: DG2+EV > DG1+EV > DG4+EV > DG3+EV

Fig.9. Show that the SPF varied values resulting from the integration of several kinds of distribution system DGs (DG1, DG2, DG3, and DG4) +EV with RLMs (RLM-1, RLM-2, RLM-3, RLM-4, and RLM-5, respectively). The variation of the SPF profile is better when DG+EV is added to DNs with RLMs and contrasted with the SPF without DG+EV, which is computed as 0.7173. The best SPFs (0.9707) for RLM5 are achieved in case of DG2+EV whereas the poorest SPFs (0.8408) for RLM4 are achieved in case DG3+EV. These are the SPFs with RLMs in decreasing order.: DG2+EV > DG1+EV > DG4+EV > DG3+EV.

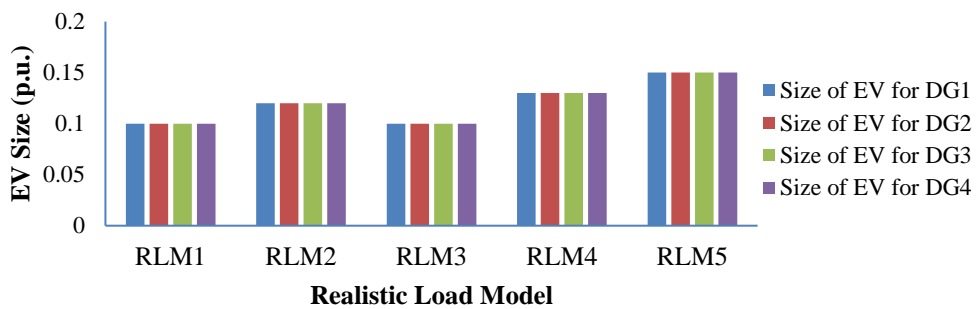

Fig.5: Comparison of various optimal EV size (p.u.) profile of 16-bus system for RLMs

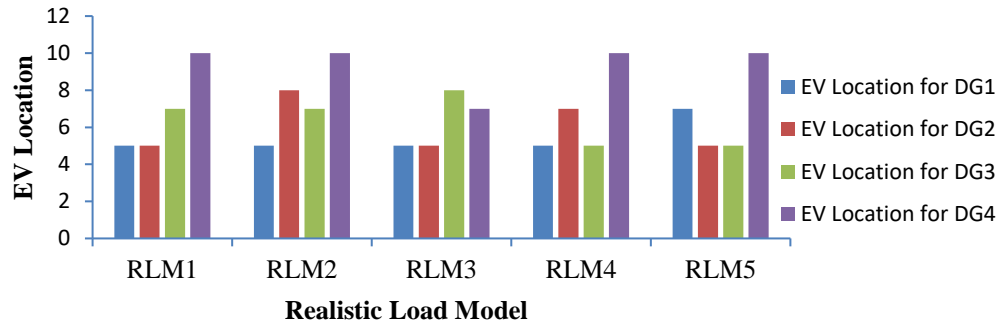

Fig.6: Comparison of various optimal EV location profile of 16-bus system for RLMs

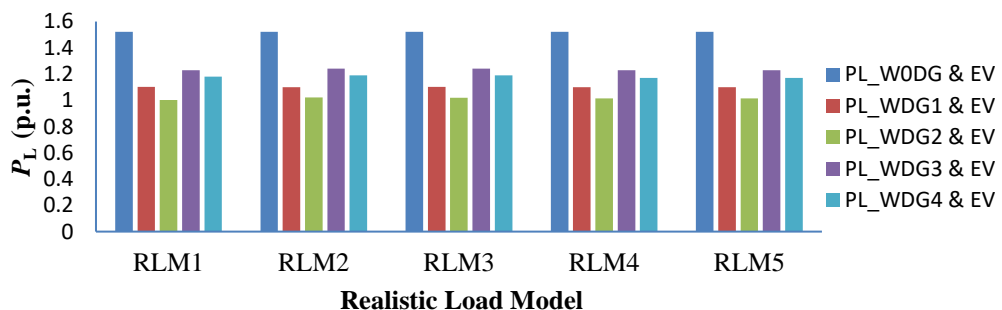

Fig.7: Comparison of P_L (p.u.) profile without and with DGs and EV of 16-bus system for RLMs

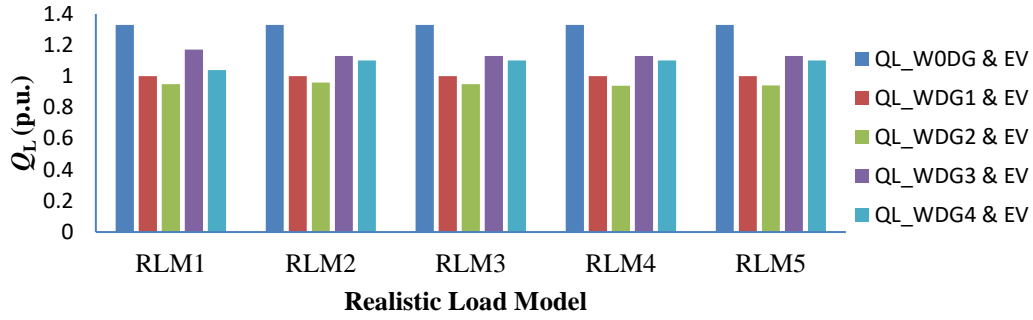

Fig.8: Comparison of Q_L (p.u.) profile without and with DGs and EV of 16-bus system for RLM

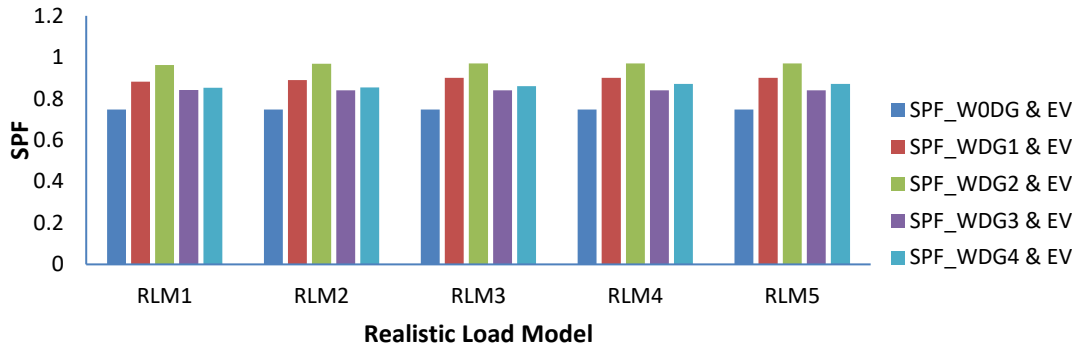

Fig.9: Comparison of SPF profile without and with DGs and EV of 16-bus system for RLMs

Table 8: Penetration of different types of DGs with EV and SPF profile planning in 37-Bus system with RLMs (ZIP+IM)

RLMs		EV										
(ZIP+IM)	DG with EV	DG Type	DG P.F.	Optimal DG Size $S_{DG(p.u.)}$	Optimal EV Size $S_{EV(p.u.)}$	DG Loc.	Loc.	P_L (p.u.)	Q_L (p.u.)	P_G (p.u.)	Q_G (p.u.)	SPF Profile
RLM1	WODG&EV	-	-	-	-	-	-	0.1609	0.1410	0.3702	0.3517	0.7550
	WDG	DG1	1.00	0.0573	-	14	-	0.1203	0.1012	0.4121	0.3515	0.7910
		DG2	0.85 ld	0.0852	-	25	-	0.0921	0.0903	0.4198	0.3510	0.8101
		DG3	0.00	0.0502	-	25	-	0.1413	0.1203	0.3717	0.3601	0.7556
		DG4	0.85 lg	0.0514	-	25	-	0.1402	0.1200	0.3751	0.3605	0.7620
	WDG & EV	DG1+EV	1.00	0.0573	-0.040	14	25	0.0832	0.0611	0.4423	0.3212	0.9001
		DG2+EV	0.85 ld	0.0852	-0.040	25	14	0.0432	0.0423	0.4678	0.3112	0.9821
		DG3+EV	0.00	0.0502	-0.040	25	18	0.1102	0.0914	0.3810	0.3423	0.8501
DG4+EV		0.85 lg	0.0514	-0.040	19	115	0.1002	0.0902	0.3751	0.3420	0.8730	
RLM2	WODG&EV	-	-	-	-	-	-	0.1609	0.1410	0.3702	0.3517	0.7550
	WDG	DG1	1.00	0.0569	-	14	-	0.1202	0.1120	0.4120	0.3514	0.7933
		DG2	0.85 ld	0.0980	-	25	-	0.0913	0.0903	0.4190	0.3510	0.8178
		DG3	0.00	0.0523	-	26	-	0.1401	0.1202	0.3710	0.3607	0.7621
		DG4	0.85 lg	0.0614	-	25	-	0.1307	0.1201	0.3751	0.3608	0.7723
	WDG & EV	DG1+EV	1.00	0.0569	-0.052	25	25	0.0836	0.0613	0.4521	0.3271	0.9023
		DG2+EV	0.85 ld	0.0980	-0.052	26	26	0.0438	0.0422	0.4701	0.3121	0.9902

		DG3+EV	0.00	0.0523	-0.052	26	18	0.1107	0.0915	0.3821	0.3410	0.8552
		DG4+EV	0.85 lg	0.0614	-0.052	14	15	0.1003	0.0901	0.3801	0.3401	0.8791
RLM3	WODG&EV	-	-	-	-	-	-	0.1609	0.1410	0.3702	0.3517	0.7550
	WDG	DG1	1.00	0.0612	-	14	-	0.1203	0.1102	0.4127	0.3515	0.8001
		DG2	0.85 ld	0.0832	-	26	-	0.1013	0.0925	0.4199	0.3501	0.8371
		DG3	0.00	0.0604	-	27	-	0.1321	0.1250	0.3801	0.3607	0.7701
		DG4	0.85 lg	0.0711	-	25	-	0.1234	0.1203	0.3712	0.3601	0.7831
	WDG & EV	DG1+EV	1.00	0.0612	-0.048	26	25	0.0821	0.0611	0.4671	0.3221	0.9039
		DG2+EV	0.85 ld	0.0832	-0.048	27	14	0.0418	0.0420	0.4521	0.3131	0.9901
		DG3+EV	0.00	0.0604	-0.048	27	27	0.1098	0.0910	0.3800	0.3423	0.8537
		DG4+EV	0.85 lg	0.0711	-0.048	25	25	0.1001	0.0900	0.3751	0.3420	0.8795
RLM4	WODG&EV	-	-	-	-	-	-	0.1609	0.1410	0.3702	0.3517	0.7550
	WDG	DG1	1.00	0.0743	-	14	-	0.1207	0.1035	0.4172	0.3512	0.7805
		DG2	0.85 ld	0.1021	-	25	-	0.0923	0.0920	0.4280	0.3601	0.8456
		DG3	0.00	0.0624	-	25	-	0.1479	0.1251	0.3801	0.3603	0.7578
		DG4	0.85 lg	0.0735	-	25	-	0.1440	0.1204	0.3721	0.3621	0.7712
	WDG & EV	DG1+EV	1.00	0.0743	-0.041	14	25	0.0831	0.0621	0.4692	0.3212	0.9103
		DG2+EV	0.85 ld	0.1021	-0.041	25	14	0.0430	0.0430	0.4701	0.3112	0.9981
		DG3+EV	0.00	0.0624	-0.041	25	15	0.1100	0.0916	0.3901	0.3412	0.8598
		DG4+EV	0.85 lg	0.0735	-0.041	25	10	0.1001	0.0912	0.3721	0.3401	0.8801
RLM5	WODG&EV	-	-	-	-	-	-	0.1609	0.1410	0.3702	0.3517	0.7550
	WDG	DG1	1.00	0.0633	-	14	-	0.1301	0.1101	0.4121	0.3501	0.7910
		DG2	0.85 ld	0.1103	-	30	-	0.1107	0.1030	0.4190	0.3512	0.8520
		DG3	0.00	0.0503	-	27	-	0.1308	0.1292	0.3717	0.3701	0.7610
		DG4	0.85 lg	0.0502	-	25	-	0.1299	0.1270	0.3691	0.3608	0.7778
	WDG & EV	DG1+EV	1.00	0.0633	-0.045	14	27	0.0840	0.0616	0.4621	0.3212	0.9003
		DG2+EV	0.85 ld	0.1103	-0.045	30	25	0.0438	0.0421	0.4727	0.3171	0.9821
		DG3+EV	0.00	0.0503	-0.045	25	14	0.1100	0.0912	0.3871	0.3501	0.8501
		DG4+EV	0.85 lg	0.0502	-0.045	27	30	0.1001	0.0900	0.3710	0.3398	0.8771

The variation of optimal EV size for RLMs in distribution systems are given in Fig.10. The optimal size of EV (0.052 p.u.) is maximum in RLM2 and (0.040 p.u.) minimum in RLM1 load model in comparison to other load model for all type of DGs (like DG1, DG2, DG3 & DG4).

Fig.11. Show the optimal EV location and Fig.12. show how the true power loss profile changes for RLMs both with and without DGs & EV. Comparing the RLM3 load model with DG1+EV, the real power loss decrease (0.0821 p.u.) is noteworthy when compared to other LMs. Therefore, bus 25 is the best place for DG1+EV to be located. When DG2+EV is used in the RLM3 load model, the real power loss decrease (0.0418 p.u.) is also noteworthy. Therefore, bus 14 is the best places for DG2+EV to be. In the RLM3 load model, the real power loss reduction of 0.1098 p.u. using DG3+EV is noteworthy. Hence, bus 27 is the best place for DG3+EV to be. With RLM3, RLM4, RLM5 load conditions, the actual power loss (0.1001 p.u.) is also at a minimum for DG4+EV, and bus 25, 10 & 30 with 0.85 lag power factor is the best bus site for DG4+EV deployment. Based on the analysis, bus 14 with DG2+EV

for real power loss reduction is the best position in the RLM3 load model condition because DG2+EV provides the system with both reactive and real power at leading power factors of 0.80 to 0.99. The best real power loss reduction with RLMs are achieved in case of DG2+EV whereas the poorest real power loss reduction with RLMs are achieved in case DG3+EV. The descending order of real power loss reduction with RLMs are as follows: DG2+EV > DG1+EV > DG4+EV > DG3+EV

The reactive power loss profile variation for RLMs with and without DGs+EV is displayed in Fig. 13. In the RLM1 and RLM3 load model, DG1+EV significantly reduces reactive power loss (0.0611 p.u.) as compared to other LMs. With DG2+EV having a 0.85 lead power factor in the RLM3 load model, the reduction in reactive power loss (0.0420 p.u.) is also noteworthy. In the RLM3 load model, the reduction in reactive power loss (0.0910 p.u.) using DG3+EV is noteworthy. For DG4+EV, the minimal reactive power loss (0.0900 p.u.) under RLM3 & RLM5 load conditions corresponds to a 0.85 lag power factor. When using RLMs, DG2+EV achieves the best reduction in reactive power loss, whereas DG3+EV achieves the lowest decrease in reactive power loss. The descending order of reactive power loss reduction with RLMs are as follows: DG2+EV > DG1+EV > DG4+EV > DG3+EV

Fig.14. Show that the SPF varied values resulting from the integration of several kinds of distribution system DGs (DG1, DG2, DG3, and DG4) +EV with RLMs (RLM-1, RLM-2, RLM-3, RLM-4, and RLM-5, respectively). The variation of the SPF profile is better when DG+EV is added to DNs with RLMs and contrasted with the SPF without DG+EV, which is computed as 0.7250. The best SPFs (0.9681) for RLM4 are achieved in case of DG2+EV whereas the poorest SPFs (0.8201) for RLM1 & RLM5 are achieved in case DG3+EV. These are the SPFs with RLMs in decreasing order.: DG2+EV > DG1+EV > DG4+EV > DG3+EV.

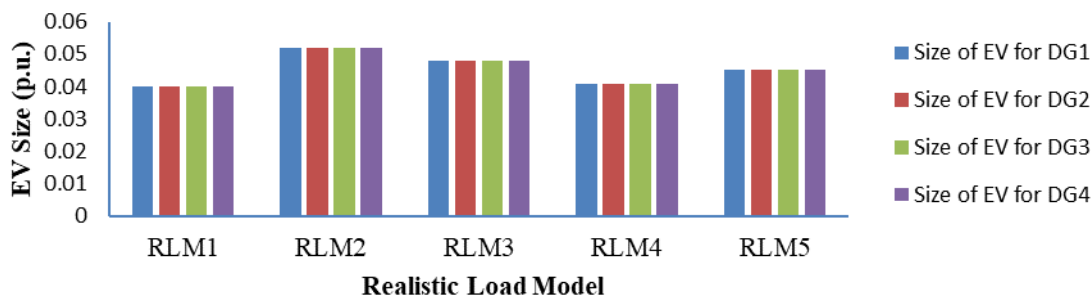

Fig.10: Comparison of various optimal EV size (p.u.) profile of 37-bus system for RLMs

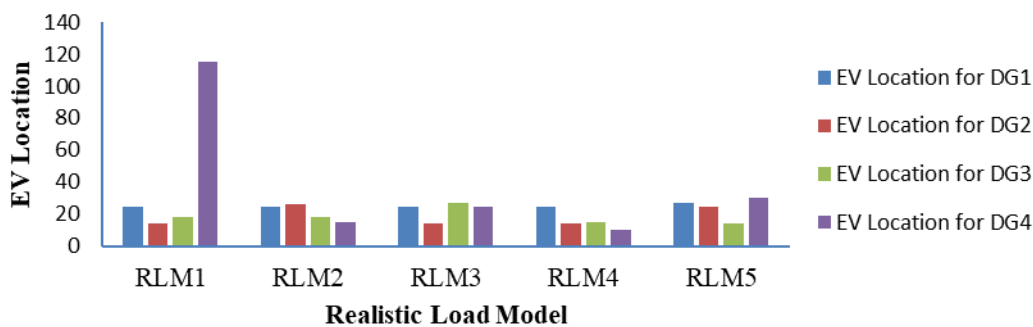

Fig.11: Comparison of various optimal EV location profile of 37-bus system for RLMs

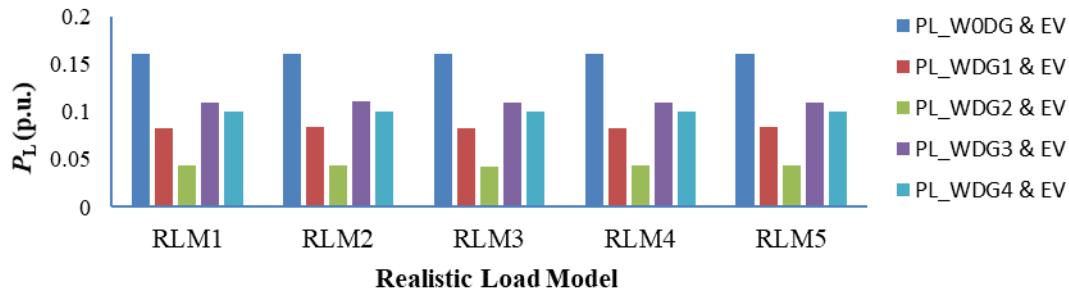

Fig.12: Comparison of PL (p.u.) profile without and with DGs & EV of 37-bus system for RLMs

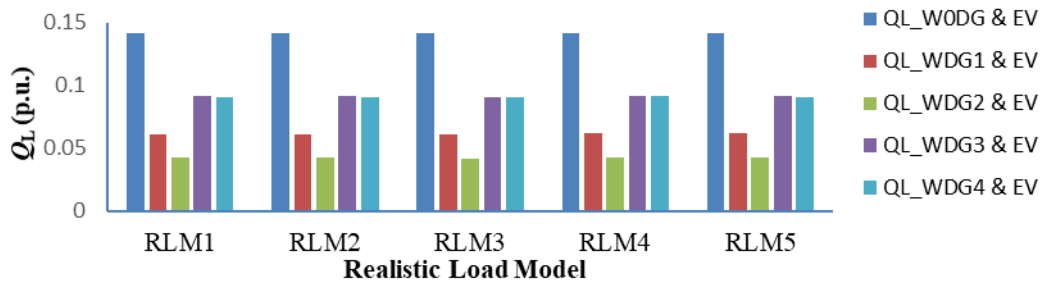

Fig.13: Comparison of QL (p.u.) profile without and with DGs & EV of 37-bus system for RLMs

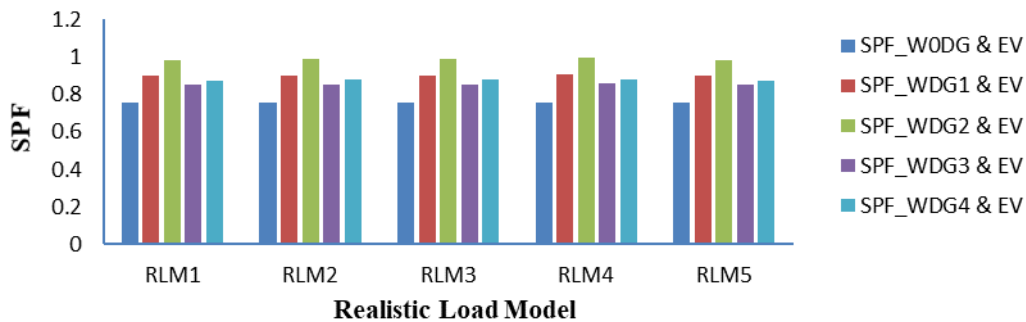

Fig.14: Comparison of SPF profile without and with DGs & EV of 37-bus system for RLMs

V. CONCLUSIONS AND FUTURE SCOPE OF RESEARCH WORK

The conclusions and future scope of research work are presented in Subsections A and B.

A. Conclusions

The following conclusion made from this research work as follows:

- Find optimal size and location of different types of DGs (i.e. DG1, DG2, DG3 and DG4 respectively) by integration of EVs for IEEE-16 and 37- bus system in DNs with various RLMs.
- The system actual and reactive power losses should be kept to a minimum by placing and sizing of DGs with EVs in DNs with RLMs appropriately.
- In comparison of the current method, hybrid MC-GA optimization technique can provide prompt and precise results.
- The performance order of different type of DGs when coordinated with EVs (DGs+EV) for RLMs are: (DG2+EV)> (DG1+EV)> (DG4+EV)> (DG3+EV).
- Boost the system actual and reactive power support by integration of various type of DGs and EVs in 16 and 37-bus system.

- The SPF is strongly enhanced when DGs, incorporated EV penetrates in the DNs with RLMs by hybrid MC-GA optimization than without DGs and EV.

B. Future scope of research work

The scientific activity in this approach has the following future scopes:

- The proposed methodology can also be used for DG and EVs integration with EVs other FACTS controller such as dynamic voltage restoral (DVR), distributed-STATCOM, unified power flow controller (UPQC), hybrid power flow controller (HPFC) and static var compensator (SVC) etc. for RLMs.
- In the future, integrate DGs with EVs and other FACTS controllers for the Western Electricity Coordinating Council's (WECC) complicated road model, artificial neural network-based modeling, and complex load model (CLOD) to improve the SPF and reduce actual and reactive power losses.
- For the purpose of validating the suggested methodology's resilience, it is also employed for higher IEEE bus test systems, such as IEEE-57, IEEE-75, 246-Indian test system, etc.
- Further, enhanced additional power system performance parameters by DGs with EVs penetration in DNs with RLMs include power quality parameters (distortion harmonic, voltage sag and swell, etc.).
- In future, enhance the SPF and minimize real and reactive power losses by integration of DGs, EVs with SVC & UPSC for RLMs on the bases of proposed methodology.

ACKNOWLEDGMENT

Mr. Ramesh is thankful to Integral University, Lucknow, UP-226026 (India), for providing Manuscript Communication Number (MCN): IU/R&D/2024-MCN0003203 and also thankful to Department of Electrical Engineering, Kamla Nehru Institute of Technology, Sultanpur, Uttar Pradesh-228118 (India) for providing all the facilities for carrying out this work.

REFERENCES

- [1] Li H, Chen Q, Fu C, Yu Z, Shi D and Wang Z 2019 Bayesian Estimation on Load Model Coefficients of ZIP and Induction Motor Model. *Energies*.12(3): 547, <https://doi.org/10.3390/en12030547>.
- [2] Singh B and Yadav MK 2018 GA for enhancement of system performance by DG incorporated with D-STATCOM in distribution power networks. *Journal of Electrical Systems and Information Technology*. 5(3): 388-426, <https://doi.org/10.1016/j.jesit.2018.02.005>.
- [3] Abdelaziz MMA, Shaaban MF, Farag HE and El-Saadany EF 2014 A Multistage Centralized Control Scheme for Islanded Microgrids With PEVs. *IEEE Transactions on Sustainable Energy*. 5(3): 927-937, doi: 10.1109/TSTE.2014.2313765.
- [4] Madawala UK and Thrimawithana DJ 2011 A Bidirectional Inductive Power Interface for Electric Vehicles in V2G Systems. *IEEE Transactions on Industrial Electronics*. 58(10): 4789-4796, doi: 10.1109/TIE.2011.2114312.
- [5] Singh D, Singh D and Verma KS 2009 Multiobjective Optimization for DG Planning With Load Models. *IEEE Transactions Power Systems*. 24(1): 427-436, doi:10.1109/tpwrs.2008.2009483.
- [6] Paterakis NG, Erdinç O, Bakirtzis AG and Catalao JPS 2015 Optimal Household Appliances Scheduling Under Day-Ahead Pricing and Load-Shaping Demand Response Strategies. *IEEE Transactions on Industrial Informatics*. 11(6): 1509-1519, DOI:10.1109/TII.2015.2438534.
- [7] Pooja S and Sameena EM 2017 Placement and sizing of distributed generation on distribution systems with a multi-objective particle swarm optimization and analytical approach: A review. *Int. J. Comput. Appl.* 161(12): 21-24, doi:10.5120/ijca2017913111
- [8] Jorge MB, Hector VO, Migue LG and Hector PD 2014 Multi-fault service restoration in distribution networks considering the operating mode of distributed generation. *Electr Pow Syst Res*. 116: 67-76, <https://doi.org/10.1016/j.epsr.2014.05.013>.
- [9] Khursheed M, Mallick MA, Iqbal A 2021 Tuning of Controllers for a Boost Converter used to Interface Battery Source to BTS Load of a Telecommunication Sitel. *Renewable Power for Sustainable Growth*, LNEE, Springer, Singapore. 723(1): 415-426, https://doi.org/10.1007/978-981-33-4080-0_40.

- [10] Ramesh, Khursheed M and Singh B 2024 Optimal Integration of DGs in Distribution Networks using Realistic Load Models with Hybrid MC-GA Technique. *Journal of Electrical Systems*. 20(7s): 3916-3932, <https://journal.esrgroups.org/jes/article/view/4484/3304> .
- [11] Foster JM, Trevino G, Kuss M and Caramanis MC 2013 Plug-In Electric Vehicle and Voltage Support for Distributed Solar: Theory and Application. *IEEE Systems Journal*. 7(4): 881-888, doi: 10.1109/JSYST.2012.2223534.
- [12] Arani MFM and Mohamed YAM 2018 Cooperative Control of Wind Power Generator and Electric Vehicles for Microgrid Primary Frequency Regulation. *IEEE Transactions on Smart Grid*. 9(6): 5677-5686, doi: 10.1109/TSG.2017.2693992.
- [13] Vimlesh, Mukharjee V and Singh B 2021 Hybrid GA-MCS based optimization for distributed generation with dynamic voltage restorer planning in distribution networks. *International Transactions on Electrical Energy Systems*. 31: e13236, <https://doi.org/10.1002/2050-7038.13236>.
- [14] Payasi R, Singh A and Singh D 2011 Review of distributed generation planning: objectives, constraints, and algorithms. *International Journal of Engineering, Science and Technology*. 3: 133-153, DOI:10.4314/ijest.v3i3.68430.
- [15] Khan I, Mallick MA, Rafi M & Mirza MS 2015 Optimal placement of FACTS controller scheme for enhancement of power system security in Indian scenario. *Journal of electrical systems and information technology*. 2(2): 161-171, <https://doi.org/10.1016/j.jesit.2015.03.013>.
- [16] Siddiqui MA, Anwar MN & Laskar SH 2020 Tuning of PIDF controller in parallel control structure for integrating process with time delay and inverse response characteristic. *Journal of Control, Automation and Electrical Systems*. 31: 829-841, <https://doi.org/10.1007/s40313-020-00603-x>.
- [17] Shahabuddin M, Riyaz A., Asim M, Shadab MM, Sarwar A & Anees A 2018 Performance based analysis of solar PV emulators: a review. *International Conference on Computational and Characterization Techniques in Engineering & Sciences (CCTES)* (pp. 94-99). IEEE, doi: 10.1109/CCTES.2018.8674082.
- [18] Fernandez Pieltain L, Roman San TG, Cossent R, Domingo Mateo C and Frias P 2011 Assessment of the Impact of Plug-in Electric Vehicles on Distribution Networks. *IEEE Transactions on Power Systems*. 26(1): 206-213, doi: 10.1109/TPWRS.2010.2049133.
- [19] Paterakis NG, Erdinc O, Bakirtzis AG and Catalao JPS 2015 Optimal Household Appliances Scheduling Under Day-Ahead Pricing and Load-Shaping Demand Response Strategies. *IEEE Transactions on Industrial Informatics*. 11(6): 1509-1519, doi: 10.1109/TII.2015.2438534.
- [20] Arif A, Wang Z, Wang J, Mather B, Bashualdo H and Zhao D 2018 Load Modelling-A Review. *IEEE Transactions on Smart Grid*. 9(6): 5986-5999, doi: 10.1109/TSG.2017.2700436.
- [21] Bokhari A, Alkan A, Dogan R, Diaz-Aguito M, Leon F and Czarkows D et al. 2014 Experimental determination of the ZIP coefficients for modern residential, commercial, and industrial loads. *IEEE Trans Power Del*. 29(3): 1372-1381, DOI:10.1109/TPWRD.2013.2285096.
- [22] Singh B and Singh S 2019 GA-based optimization for integration of DGs, STATCOM and PHEVs in distribution systems. *Energy Reports*. 5: 84-103, <https://doi.org/10.1016/j.egy.2018.09.005>.
- [23] Shukla TN, Singh SP, Shrinivasarao V and Naik, KB 2010 Optimal sizing of distributed generation placed on radial distribution systems. *Electr. Power Components and Syst*. 38(3): 260-274, <https://doi.org/10.1080/15325000903273403>.
- [24] Khodayar ME, Wu L and Shahidehpour M 2012 Hourly Coordination of Electric Vehicle Operation and Volatile Wind Power Generation in SCUC. *IEEE Transactions on Smart Grid*. 3(3): 1271-1279, doi: 10.1109/TSG.2012.2186642.
- [25] Deb G, Chakraborty K and Deb S 2020 Modified Spider Monkey Optimization-Based Optimal Placement of Distributed Generators in Radial Distribution System for Voltage Security Improvement. *Electric Power Components and Systems*. 48(9-10): 1006-1020, <https://doi.org/10.1080/15325008.2020.1829186>.
- [26] Sulaiman MH, Mustafa MW, Azmi A, Aliman O and Rahim SRA 2012 Optimal allocation and sizing of distributed generation in distribution system via firefly algorithm. *IEEE Int. Power Eng. and Optimization Conf. Melaka, Malaysia*. 84-89, doi: 10.1109/PEOCO.2012.6230840.
- [27] Singh B, Verma A, Chandra A and Al-Haddad K 2020 Implementation of Solar PV-Battery and Diesel Generator Based Electric Vehicle Charging Station. *IEEE Transactions on Industry Applications*. 56(4): 4007-4016, doi: 10.1109/TIA.2020.2989680.
- [28] Su Z, Wang Y, Xu Q, Fei M, Tian Y and Zhang N 2019 A Secure Charging Scheme for Electric Vehicles With Smart Communities in Energy Blockchain. *IEEE Internet of Things Journal*. 6(3): 4601-4613, doi: 10.1109/JIOT.2018.2869297.

- [29] Singh B, Mukherjee V and Tiwari P 2016a Genetic algorithm for impact assessment of optimally placed distributed generations with different load models from minimum total MVA intake viewpoint of main substation. *Renewable Sustainable Energy Rev.* 57: 1611-1636, <https://doi.org/10.1016/j.enbuild.2016.05.033>.
- [30] Singh B, Mukherjee V and Tiwari P 2017 GA-based multiobjective optimization for distributed generations planning with DLMs in distribution power systems. *J. Electr. Syst. Inf. Technol.* 4(1): 62-94, <https://doi.org/10.1016/j.jesit.2016.10.012>.
- [31] Zhang D, Fu Z and Zhang L 2008 Joint optimization for power loss reduction in distribution system. *IEEE Trans. Power Syst.* 23(1): 161-169, DOI: 10.1109/TPWRS.2007.913300.
- [32] Vimlesh, Mukherjee V and Singh B 2021 Hybrid GA-MCS based optimization for integration of DG, DVR, and DSTATCOM planning in distribution networks. *International Transactions on Electrical Energy Systems.* 31: e13223, <https://doi.org/10.1002/2050-7038.13223>.
- [33] Singh D, Singh D and Verma KS 2009 Multi-objective optimization for DG planning with load models. *IEEE Trans. Power Syst.* 24(1): 427-36, doi: 10.1109/TPWRS.2008.2009483.
- [34] Singh D, Mishra RK and Singh D 2007 Effect of load models on distributed generation planning. *IEEE Trans. Power Syst.* 22 (4): 2204-2212, DOI:10.1109/TPWRS.2007.907582.
- [35] Patel DK, Singh D and Singh B 2020 Genetic algorithm-based multi-objective optimization for distributed generations planning in distribution systems with constant impedance, constant current, constant power load models. *Int. Trans. Electr. Energy Syst.* 30(11), doi.org/10.1002/2050-7038.12576.
- [36] Singh RK and Goswami SK 2009 Optimum siting and sizing of distributed generations in radial and networked systems. *Electr. Power Compon. Syst.* 37(2): 127-145, <https://doi.org/10.1080/15325000802388633>.
- [37] Singh RK and Goswami SK 2011 Multi-objective optimization of distributed generation planning using impact indices and trade-off technique. *Electr. Power Syst. Res.* 39(11): 1175-1190, <https://doi.org/10.1080/15325008.2011.559189>.
- [38] Singh RK and Goswami SK 2010a Optimum allocation of DGs based on nodal pricing for profit, loss reduction, and voltage improvement including voltage rise issue. *Int. J. Electr. Power Energy Syst.* 32(6): 637-644, <https://doi.org/10.1016/j.ijepes.2009.11.021>.
- [39] Singh B, Mukherjee V and Tiwari P 2015. A survey on impact assessment of DG and FACTS controllers in power systems. *Renewable and Sustainable Energy Rev.* 42: 846-882, <https://doi.org/10.1016/j.rser.2014.10.057>.
- [40] Sanjaka GW and Ali E 2011 Classification and review of control strategies for plug-in hybrid electric vehicles. *IEEE Trans. Vehicular Technol.* 60(1): 111-122, doi: 10.1109/TVT.2010.2090178.