

¹Isha Rajput
²Jyoti Verma
³Hemant Ahuja

Improving Microgrid Stability and Performance using PID Fuzzy Logic-Based Control: A Comprehensive Evaluation



Abstract: -

Microgrids (MGs), comprising distributed energy resources like solar panels, wind turbines, and batteries, offer decentralized and resilient power solutions. However, ensuring stability and optimal performance in such systems presents challenges, especially given the variability of renewable energy sources and dynamic load demands. This study investigates the enhancement of microgrid stability and performance through the utilization of a Proportional-Integral-Derivative (PID) fuzzy logic-based control system tailored specifically for a hybrid Photovoltaic (PV) -Wind-Battery MG. By integrating Maximum Power Point Tracking (MPPT) techniques and precise controller design, the approach aims to optimize power production under diverse environmental conditions. Results show voltage stabilization from 255V to 275V within 2s, with consistent grid power output at approximately 8.6×10^4 W. Wind turbine performance exhibits stable voltage responses around 20V, while the State of Charge (SOC) of the Battery Energy Storage System (BESS) declines from 50% to 49.093% over 5s. These findings validate the efficacy of advanced control strategies in optimizing microgrid operation, laying a foundation for resilient energy infrastructure. Overall, the study demonstrates the potential of advanced control strategies for optimizing microgrid operation and fostering resilient energy infrastructure.

Keywords: Microgrid, PID controller, Fuzzy Logic, Renewable energy sources, Maximum Power Point Tracking

I. INTRODUCTION

Smart grid principles are becoming increasingly essential for the evolution of power systems, with a particular focus on flexible microgrids (MGs) [1-3]. These MGs operate both in grid-connected and island modes [4], prioritizing renewable energy sources over auxiliary ones, such as diesel-powered ones [5]. The use of renewable energy resources not only makes MGs stable, easy to adapt, and budget-friendly but also aligns with environmental sustainability [6-8]. The integration of small sources of power into the marketplace is made possible by MGs, which improves the overall efficacy of the system, ensure the reliability of the power supply, and provide consumers control over their power supply [9]. Additionally, ensuring stability within microgrids is paramount to their successful operation, and advanced control strategies such as PID fuzzy logic-based control play a crucial role in maintaining this stability; as shown in Figure 1, an MG consists of many components that work together to form an intelligent Energy Management System (EMS) [10].

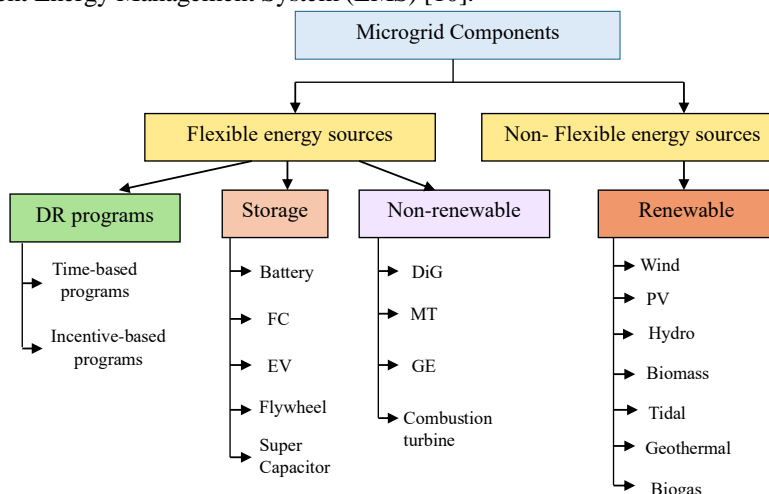

Figure 1. Various components of MG [11]

¹ *Corresponding author: Department of Electrical and Electronics Engineering, Manav Rachna International Institute of Research and Studies, Faridabad, Haryana, India, isharajput2730@gmail.com

² Department of Electronics and Communication Engineering, Manav Rachna International Institute of Research and Studies, Faridabad, Haryana, India, jyotiverma.fet@mriu.edu.in

³ Ajay Kumar Garg Engineering College Ghaziabad, Uttar Pradesh, India, ahuja.iitd@gmail.com

MG safety and stability pose challenges due to the diversity of power sources. Factors such as load demand and distributed generation (DG) awareness impact the MG structure during design and operation, requiring robust construction and control approaches [12-14]. The use of conventional control methods has been utilized in order to ensure the stability of voltage and frequency, with hierarchical control systems modulating MG voltage and frequency based on power generation information [15].

The interest in direct current distribution systems (DCDS) has risen, particularly for MG units like Alternating Current (AC) and hybrid. The low-voltage DCDS is gaining traction for residential and commercial purposes [16]-[17]. However, maintaining and controlling microgrid voltage in AC/DC systems remains a question, necessitating effective control mechanisms. Previous studies on MG voltage control mainly focus on droop concepts [18-21]. Controlling schemes for line current compensation using conventional controllers are widely utilized [22], whereas PI controllers are commonly used for DC bus voltage control [23]-[24]. PID controllers, though simple and widely used in industrial applications, face challenges in tuning parameters for higher-order systems [25-27] which led to a growing shift towards Fuzzy Logic Controllers (FLCs).

The efficacy of FLCs in adjusting to input changes and their simpler mathematics have led to their recent use in a variety of applications. Instead of being model-based like traditional controllers, fuzzy controllers are knowledge-based [28]-[29]. The FLC modifies the input-output relationship in a nonlinear way. In order to attain the target system performance with minimal mathematical effort, these controllers may be fine-tuned. Traditional PID controllers use three metrics—input error, integral of error, and derivative of error—to optimize their performance [30]. Incorporating fuzzy logic into PID-Controller the three parameters could be modified or adjusted by experience-based knowledge. Fuzzy-based PID controllers allow the specific error rate change without having to delve into a mathematical model.

An active response is necessary since the process of differentiating and integrating varies over time and is influenced by previous events. The variations in the demand for solar PV electric power result in changes in the amount of energy consumed by public utilities. The MG voltage becomes more variable as a result of this modification. Hence, a control action is required to keep the MG voltage at the required reference level. Therefore, to address this issue and enhance additional flexibility, a PID controller based on fuzzy logic was used in the present study. Combining PID control knowledge with Fuzzy logic understanding, the study presents the design of a PID-FLC system for an MG.

II. REVIEW OF LITERATURE

In this section, some related work based on the performance evaluation of MGs is presented below:

Sumarmad et al., (2022) [31] proposed a new EMS for MGs using robust control and real-time monitoring. Power flow in the MG was controlled by the FLC and enhanced frequency/voltage regulation. The study used ThingSpeak to monitor data in real-time, highlighting enhanced load management performance. Simulation results conducted on MATLAB proved the viability and effectiveness of the proposed approach under various operating conditions, highlighting the usefulness of monitoring real-time data in MG control.

Eluri et al., (2022) [32] presented a modern hybrid model integrating PV, wind turbine, and converter components to enhance MG operation, focusing on dependability and efficiency. The study employed Maximum Power Point Tracking (MPPT) to optimize PV efficiency, addressing the variability of solar energy due to temperature changes. The result revealed that the suggested FLC-based EMS had source voltage Total Harmonic Distortion (THD) of 3.30% while source current THD of 4.59%.

Al Sumarmad et al., (2022) [33] utilized smart controllers to develop a MG system with efficient Energy Management. The proposed system control integrated renewables, Li-ion batteries, and a backup main grid and monitors the SOC of the battery. The results obtained using MATLAB proved that FLC was superior in efficacy and accuracy over PID and Artificial Neural Network (ANN) controllers. The study also confirms the effectiveness of the proposed fuzzy logic-based EMS for MGs.

Alayi et al., (2021) [34] delved into the use of energy sources and control mechanisms in MGs, with a focus on planned and unplanned transitions to islanded states. The study used an MG model with a PID controller. The controller was then optimized using the Craziness-based Particle Swarm Optimization (CRPSO). Using this model, this study proved that the results of the proposed algorithm are superior to those from a PI-based controller. Altering the PID controller parameters could allow the proposed controller to achieve its desired response with minimal transient time. This would also minimize distortion in the MG.

Sharma et al. (2020) [35] explored energy management strategies to improve institutional PV systems. These systems have shown increased performance when there is an incorporation of Distributed Generation (DG) during

grid outages. The renovated system at the Energy and Resources Institute's (TERI) retreat building witnessed a significant increase in battery energy throughput from 37 % to 72 %. DG not only met total load demand during outages but also throughput by utilizing PV energy.

Elkazaz et al. (2020) [36] presented a study on Home Energy Management Systems (HEMS) and evaluated two strategies: a model predictive controller (MPC) and a real-time controller (RTC) over a year. Adjusting overnight charging based on weather predictions, the RTC achieved the highest PV self-consumption ratio at 89.70% and an 8.1% lower cost increase ratio of household energy with added operational costs. The MPC, considering forecasting errors and sample time, significantly reduced household peak energy demands by up to 35.2%. The short response time of MPC demonstrated superior performance, ensuring higher cost reductions.

Mohamed et al., (2020) [37] introduced an innovative frequency control method for an MG system employing a fractional order PID controller. The MG system comprised various energy sources and storage Systems. The primary aim of the study was to minimize power and frequency variations through the employment of the suggested controller using the Krill Herd algorithm (KHA). A comparison between the Genetic Algorithm (GA) and KHA demonstrated that the KHA-based controller yielded superior performance over GA by reducing both power and frequency deviations in simulation results. This showed the efficiency of the suggested controller for improving the stability and performance of MG systems.

Hemanand et al., (2018) [38] emphasized the effectiveness of hybrid renewable energy sources to generate electricity along with addressing environmental safety. The study provided a simulation model of a 60 kW PV and Wind power system with MATLAB Simulink and analyzed the system with different intelligent controllers such as Fuzzy logic, ANN, and ANFIS using MATLAB Simulink environment. Evaluation and comparison of simulation results supported the proposed system, suggesting its suitability for MG integration of a hybrid renewable energy system.

Mahdi et al., (2017) [39] investigated a fuzzy logic tables-based load frequency control model for isolated AC MG. They also compared this model with the conventional PI controller. Based on the results of the simulation, it was seen that the fuzzy logic table control method gives better output compared to the PI controller, especially during transients. Consequently, this means that there was effectiveness in the proposed method for improving load frequency control in isolated AC MGs.

Angalaeswari et al., (2017) [40] highlighted the increasing need for power through a growing concern on the transition to green energy. The study concentrated on the integration of FLC in managing loads within a grid-connected MG. The study utilized MPPT with an FLC in a PV and battery-based MG. The simulation results revealed that the FLC operates efficiently at different irradiation levels and load conditions. This illustrates the controller has been successful in maximizing the performance of MG.

III. RESEARCH PROBLEM

The problem of evaluating the performance of MGs is very complex due to dynamism and non-linearity that are influenced by irregular sources of renewable energy, variations in loads as well as disturbances that occur unexpectedly. For instance, these factors are so complex that they should be examined carefully and optimized for the safe performance of the system. This is because conventional control techniques tend to fail to properly address uncertainties and variability within MG systems. In addition, MGs have become important in the maintenance of resilience and sustainability across electricity distribution networks during the transition to renewable energy sources and decentralized forms of power generation. Therefore, it is necessary to investigate new control strategies that match with the changing dynamics in MGs thus mitigating problems associated with their assessment.

IV. RESEARCH METHODOLOGY

The traditional practices of controlling MGs have always employed varied control strategies. This section is a summary of the control methods and technologies employed in this study.

A. Techniques used.

The following section presents the techniques that were employed in the study:

- **Microgrid**

Mostly renewable resources are used by an MG depicted in Figure 2 that combines low- and medium-voltage hybrid power sources to supply high-quality electricity to small customers in remote or isolated rural regions [41]. MGs can operate as an islanding mode or, according to technological and economic factors, a mode connection coupled to the primary grid through a Point of Common Coupling (PCC) [42].

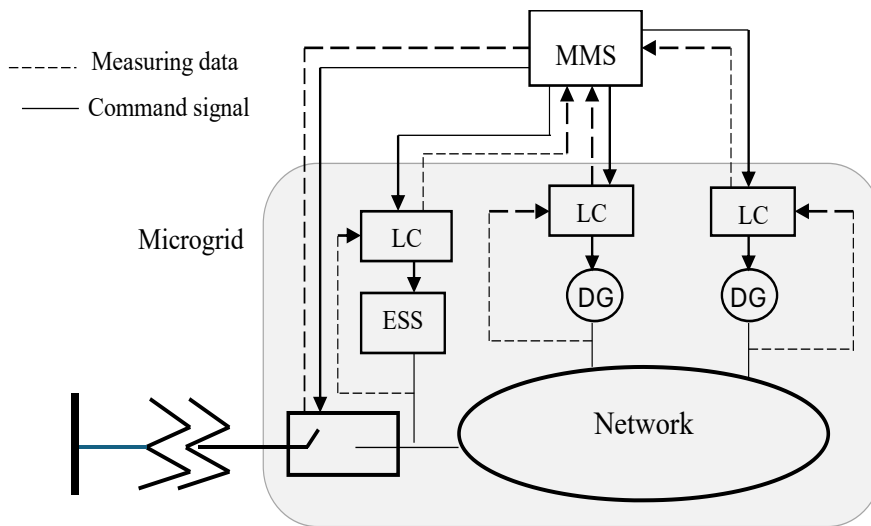

Figure 2. Hierarchical structure of MG [43]

In an MG, distributed energy sources, energy storage devices, and loads all work together. An interconnected switch located at the PCC connects the MG with the major utility grid based on conventional interface standards. On either aspect of this PCC is located an interconnection switch through which the entire MG can be linked to or disconnected from the main utility grid. In most instances, both the grid system and the MG system work side by side. The moment a disturbance takes place within the upstream network. However, it triggers its isolation mode, where it disconnects from a large power system. The management of the MG takes place on two levels - centrally and locally. This study emphasizes the use of MGs to enhance system effectiveness, power supply conditions, and user control over electrical supply [44].

- **Proportional–Integral–Derivative (PID) Technique**

Automatic controllers in industrial control systems often use PID control as a comprehensive feedback control approach. The PID controller is the accepted norm for engineering application controls; It uses the proportional function to transform an error signal into an input signal [45]. The input signals of the PID controller are the error signal, which is derived by comparing the observed output signal with the predicted reference. In order to reduce it, PID controllers analyze the error signal. A hybrid car may use a PI controller to charge the battery and maintain a constant voltage bus in the electric vehicle, all while recovering energy from regenerative braking [46]. The controller's responses might be compared to those of PID-controlled bidirectional DC-DC converters [47]. The impact of power outages or changes in load must be automatically controlled by the PID controller [48]. Whether the PID parameters inside the framework are set up correctly has a significant impact on the PID performance [49].

- **Fuzzy PID controller**

Fuzzy control relies on fuzzy logic, which has a far stronger resemblance to human thinking and natural language than traditional analytical methods [50]. Because of their dependability and longevity, fuzzy controllers can tackle a variety of control issues. Fuzzy logic, which resembles human reasoning, is better than conventional PID controllers. When applied to nonlinear systems, fuzzy control outperforms conventional PID controllers in terms of settling time and adaptability [51]. Fuzzy logic control (FLC) might also be used in the construction of an EMS. Therefore, to improve the Energy Storage System's (ESS) frequency control capability and stability to the microgrid, this study developed a fuzzy PID controller, as shown in Figure 3.

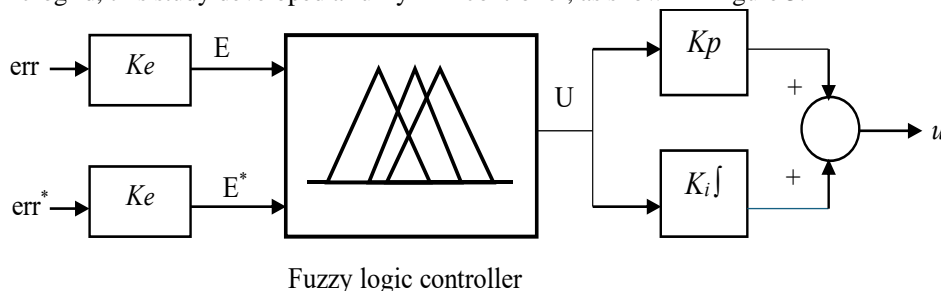

Figure 3. Fuzzy-PID controller [44]

An FLC and a traditional PID controller are connected in series to form this fuzzy-based PID controller. Firstly, 2 input signals, derivative of output (err^*) and error (err), go into the FLC then the output signal, U , is used as an input signal by the standard PI controller. The control signal (u), the traditional PI controller's output signal, is then used for MG stabilization.

B. Proposed methodology

A process to create an EMS specifically for a hybrid PV-Wind-Battery MG is proposed by the current research that is precisely designed for a hybrid PV-Wind-Battery MG. The main objective of this approach is to analyze these dynamic characteristics as well as the relationship between them in a mathematical model, which is then used to design all the necessary components of the MG. This process has led to optimal power production under varying environmental circumstances by using MPPT techniques and establishing an accurate PID-based FLC. System modelling and in-depth analysis have also resulted in better performance by configuring FLC settings and MPPT algorithms. Lastly, this implementation helps ensure safety and provides a means for validating system performance in real-world applications.

The major steps that are included in the proposed methodology are presented as follows.

Step 1. System Overview and Requirements Definition:

- Define the objectives of the EMS for the Hybrid PV and Wind MG.
- Specify the technical requirements, including the power capacity of the PV and wind systems, battery capacity, voltage levels, and other relevant parameters.
- Identify the key components such as PV panels, wind turbines, batteries, converters, and the fuzzy logic controller.

Step 2. Mathematical Modeling:

- Develop mathematical models for the Solar and Wind energy conversion systems.
- Include the dynamics of the PV panels, wind turbines, boost, and buck converters, and the battery.
- Represent the interconnections between the components.

Step 3. FLC Design:

- Initialize the FLC by defining its input and output variables.
- Find the membership functions and fuzzy sets associated with each input and output variable.
- Define the fuzzy rules that the FLC can use to make decisions.
- Implement the fuzzy inference system and defuzzification method.

Step 4. MPPT Control:

- Design MPPT algorithms for both the PV and wind energy sources.
- Integrate the MPPT control strategies into the fuzzy logic controller.
- Ensure the MPPT algorithms maximize the power output from the PV panels and wind turbines under varying environmental conditions.

Step 5. System Simulation:

- Model the entire hybrid PV-Wind-Battery MG in MATLAB/Simulink.
- Implement the FLC-based EMS and MPPT control algorithms.
- Simulate the system under several operating situations and environmental scenarios to validate the performance and efficiency of the proposed system.

Step 6. Performance Optimization and Improvement:

- Analyze simulation results to identify areas for improvement.
- Optimize FLC parameters and MPPT control algorithms for better system response.
- Evaluate the impact of different parameters on the overall system efficiency.

Step 7. Reliability and Robustness Analysis:

- Assess the reliability of the hybrid MG by considering fault scenarios.
- Implement fault detection and recovery mechanisms in the FLC.
- Evaluate the robustness of the system under uncertainties in renewable energy generation and load variations.

Step 8. Implementation and Interface with the Grid:

- Implement the FLC-based EMS on a real-time control platform or microcontroller.
- Interface the MG with the grid, if required, considering safety and regulatory standards.
- Test the system in a real-world environment and validate its performance.

Overall, this approach specifies a procedure for developing a complex MG EMS using a fuzzy-based PID controller. The process begins with establishing objectives and technical requirements, continues with

mathematical modelling and the design of an FLC, incorporates MPPT for enhanced efficiency, goes through extensive optimization, simulation, and reliability testing, and finally concludes with a real-world deployment. This ensures that the system is safe and has been validated for use in operational MGs. Overall, this approach specifies a procedure for developing a complex MG EMS using a fuzzy-based PID controller. The process begins with establishing objectives and technical requirements, continues with mathematical modelling and the design of an FLC, incorporates MPPT for enhanced efficiency, goes through extensive optimization, simulation, and reliability testing, and finally concludes with a real-world deployment. This ensures that the system is safe and has been validated for use in operational MGs.

V. RESULTS AND DISCUSSION

This section presents the results obtained from the evaluation of the proposed PID fuzzy logic-based control system designed for a hybrid PV-Wind-Battery MG.

A. Microgrid with PID fuzzy logic-based controller

The schematic representation of the Microgrid with a PID fuzzy logic-based controller shown in Figure 4 reveals a complex network of interconnected blocks and modules, each fulfilling distinct functions within the microgrid system. At the top, the MPPT Solar Charge Controller Model and MPPT Wind Charge Controller Model are depicted, linked to various components facilitating energy conversion and transmission. In the middle section, a solar power unit with fuzzy signal generation blocks and a wind power unit with a bridge rectifier circuit are illustrated. The bottom portion portrays battery energy storage and charge controller supply, demonstrating the storage and distribution of energy within the microgrid. The architecture emphasizes the incorporation of renewable energy sources, such as solar and wind power, into the grid to enhance energy management efficiency.

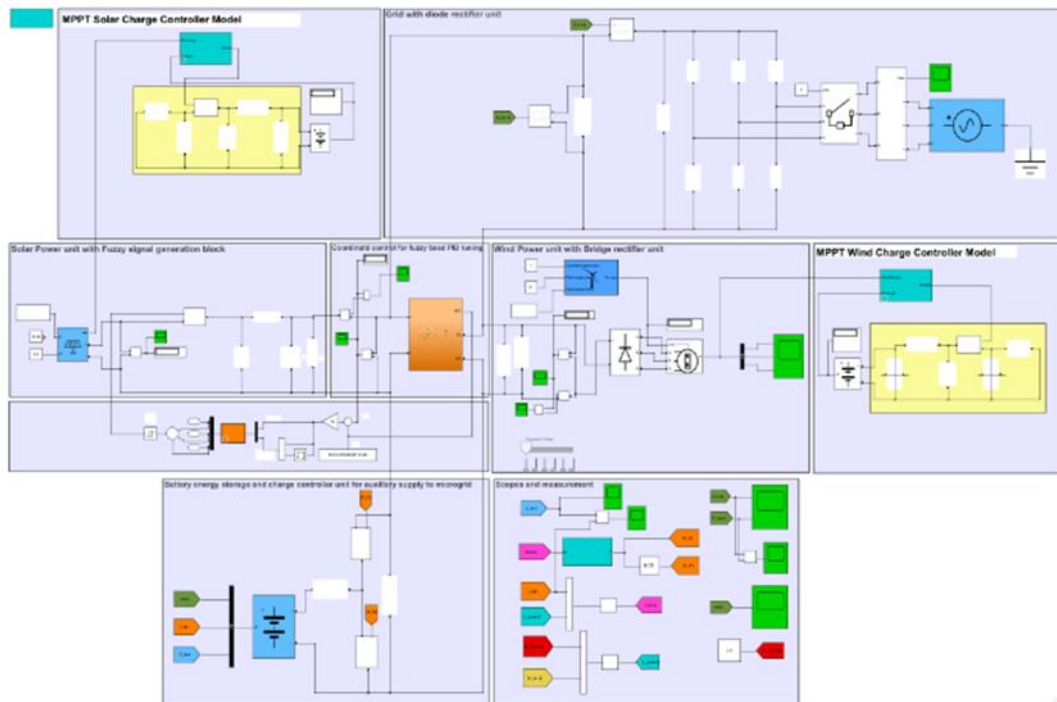

Figure 4. Microgrid with PID fuzzy logic-based controller

B. Three-phase voltage supply to the main grid

Figure 5 illustrates 3 phase grid voltage supply represented by multiple sinusoidal waves. These waves exhibit AC behaviour, with each wave oscillating between positive and negative peak voltages. The x-axis represents time ranging from 0 to approximately 0.14s, while the y-axis shows grid voltage in volts ranging from -300V to 300V.

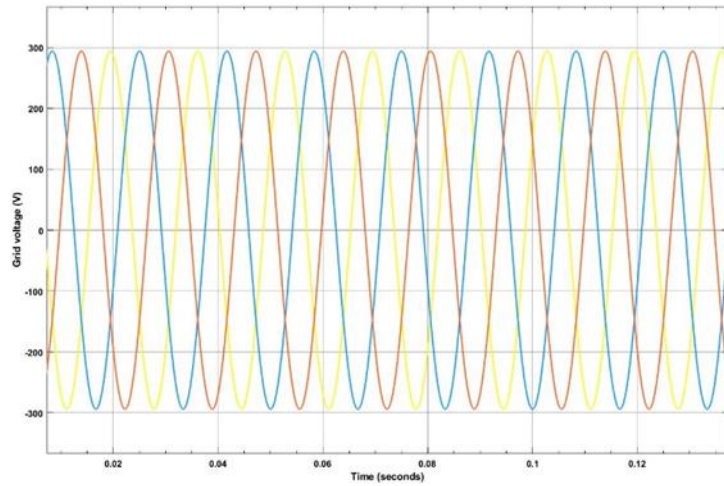

Figure 5. Three-phase voltage supply to the main grid

C. Grid Power

Figure 6 shows a graph of Grid Power over Time. The grid power is stable at approximately 8.6×10^4 W throughout the time period from 0 to 5s. The result displays a consistent grid power output over time, indicating stability and reliability in the energy supply. This is due to the controlled PID and Fuzzy-tuned response from the combined system.

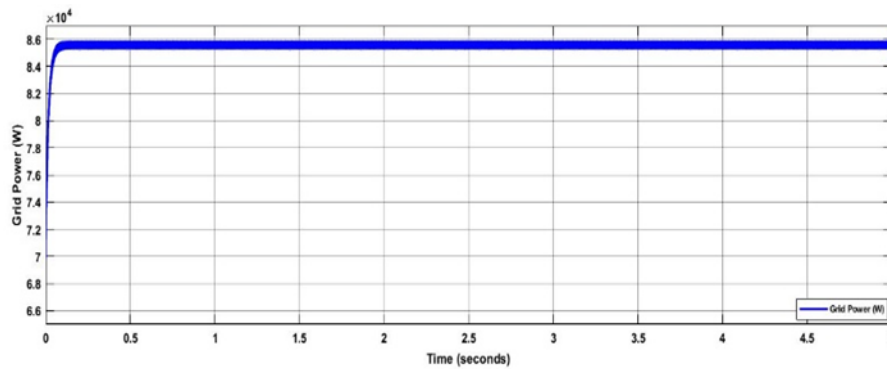

Figure 6. Grid Power

D. Solar power MPPT tracking control

Figure 7 shows a graph of Grid Power versus Time. Initially, at 0s, the Grid Power is around -7800 W. It sharply decreases to approximately -9200 W within the first second and then remains constant for the rest of the period shown in the graph. The result shows a sudden drop in grid power before stabilizing due to MPPT, indicating a significant change or event occurring at that moment, which could be crucial for analyzing power systems. This shows the solar PV system stabilizes with time supplying constant supply to the main grid.

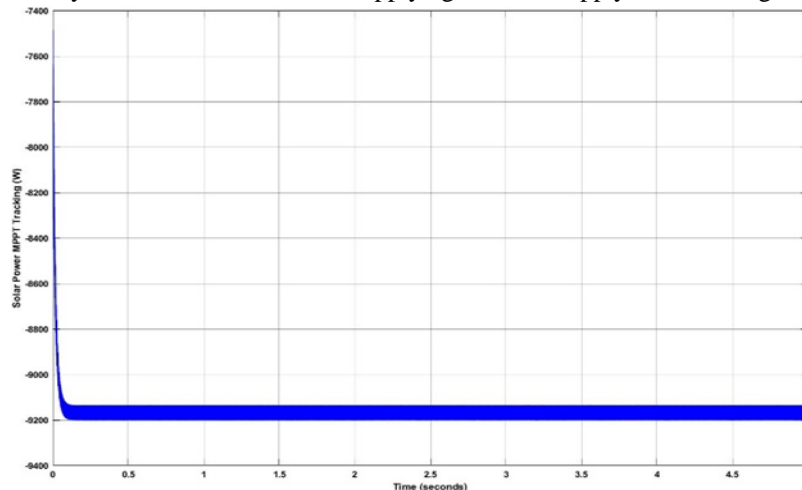

Figure 7. Solar power MPPT tracking control

E. Solar Generated Voltage

Figure 8 illustrates Grid voltage plotted against Time. Initially at 0s, the Grid Power increases from 0 to 320V, which remains constant up to 2s, then it sharply increases to 340V and again remains constant for the next 2s, then stabilizes around 350V.

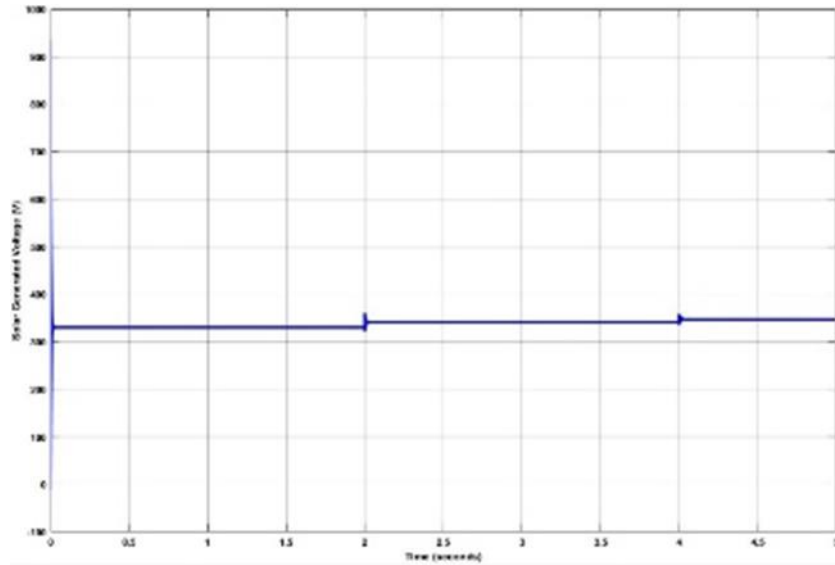

Figure 8. Solar generated voltage

F. Wind Turbine Voltage Stability

Figure 9 depicts the voltage response of a wind turbine with respect to time. The voltage remains relatively stable, fluctuating slightly but predominantly around 20V throughout the time period.

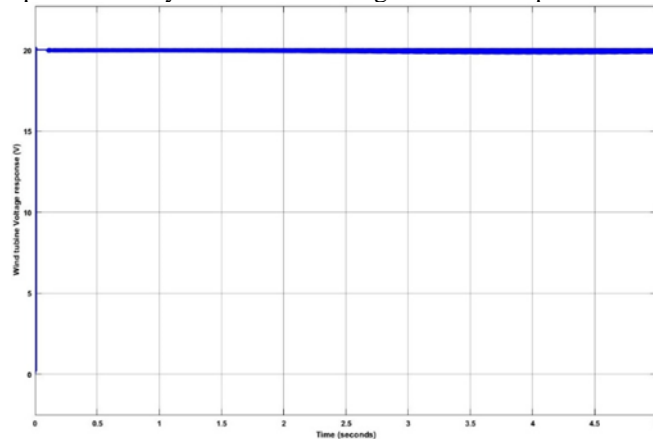

Figure 9. Wind turbine voltage stability

This stability suggests effective voltage control within a narrow range, typically between approximately 19.5 volts and 20.5 volts. This shows the stable voltage response achieved due to PID based fuzzy logic controller in the wind turbine.

G. Wind turbine MPPT tracking

Figure 10 indicates a variation between 4000W to 4200W over time. This observation suggests the wind turbine is either consistently generating its maximum power output or operating at a steady state without reaching peak efficiency.

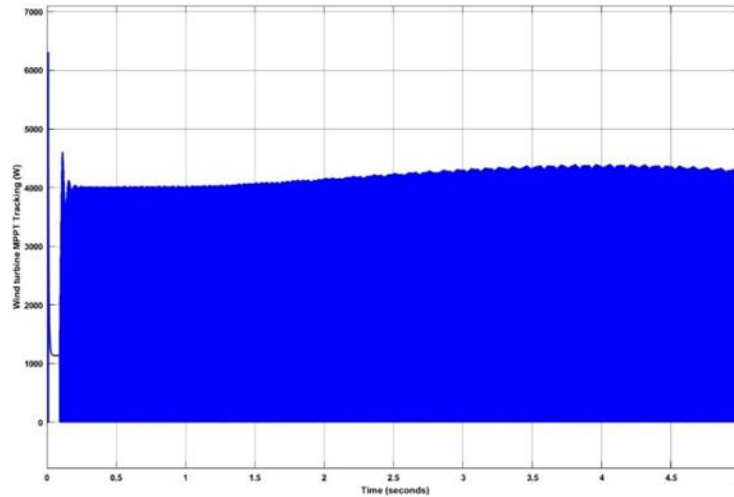

Figure 10. Wind turbine MPPT tracking

The consistent power output implies an effective MPPT control strategy in the wind turbine block. It indicates that the wind turbine is now supplying optimal power to the main grid with slight variation due to dynamic response and pitch angle variation with a change in the wind speed.

H. Wind Turbine Generator

The figure 11 depicts the wind turbine generator's performance for a time period of 5s. The Electromagnetic Torque (Nm) graph shows fluctuating values between approximately 0.005 to 0.06 Nm, indicative of rotational force variations caused by changes in wind speed, as well as mechanical load fluctuations within the wind turbine system. Similarly, the Rotor Speed (rad/sec) graph illustrates speed fluctuations, ranging from 0.5 to 6.25 rad/sec, mirroring the torque variations, and influenced by both wind speed changes and mechanical load dynamics but in opposite directions, showing negative magnitude. The Stator Current (A) graph reflects electrical current fluctuations, typically ranging from around 0.001A to 0.12A, with continuously varying stator current with time due to load fluctuations, which must be controlled using a PID-Controller. These numerical observations suggest the response of wind turbine generators to wind speed and internal system dynamics.

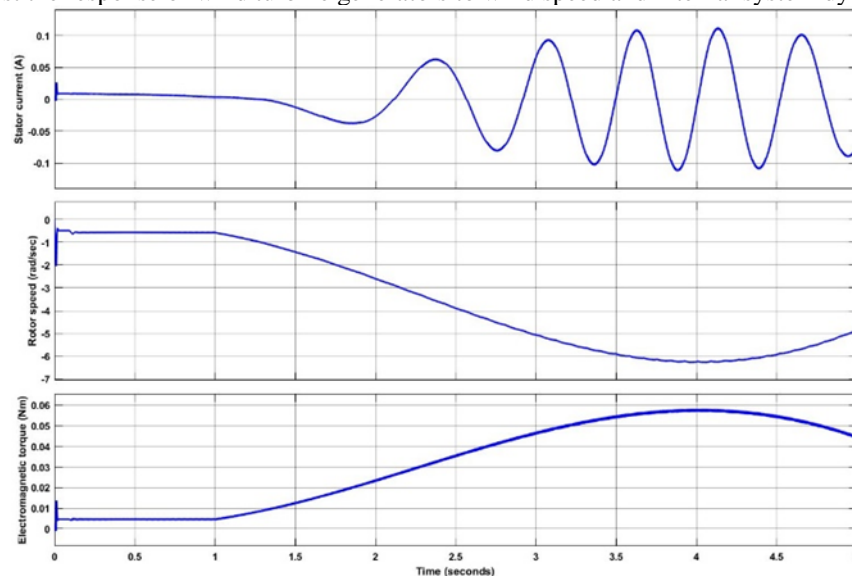

Figure 11. Wind Turbine Generator Response

I. Robustness and Reliability check

Robustness refers to the system's ability to handle uncertainties in renewable energy generation and load variations, whereas Reliability signifies consistent performance over time despite fault and load changes. Figure 12 provides insights into the robustness and reliability of the system based on its response to varying power dynamics. While the system may not solely rely on renewable sources, its ability to maintain stable performance in the face of fluctuating demand indicates robustness. Moreover, the consistent behaviour observed across both scenarios suggests a reliable and predictable operation, enhancing confidence in the system's performance under varying conditions.

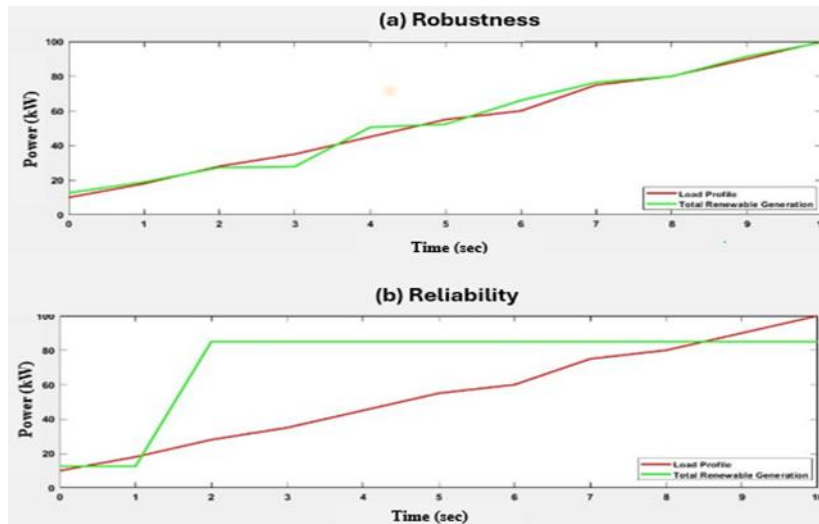

Figure 12. Robustness check Reliability check

J. Efficiency and Performance of microgrid components

Figure 13 depicts the efficiency and performance of various components within a microgrid system. It shows the efficiency of four components- Grid, Solar PV, Wind Turbine, and Battery. Each component's efficiency fluctuates over the duration. The solar PV efficiency varies between 0 to 0.75. In contrast, the microgrid varies between 0.02 to 1.1, the wind turbine efficiency decreases from 0.5 to -0.4 due to load dynamic changes, and the battery efficiency increases from -1.5 to 0 as more power from the renewable sources accumulates in the main grid; thus, it remains stable at this point. Another graph illustrates the power output of the microgrid and the power demanded by the load. Here, the microgrid power output increases up to 84.9 kW and becomes constant according to the power availability from the multiple energy sources while the load profile continuously increases.

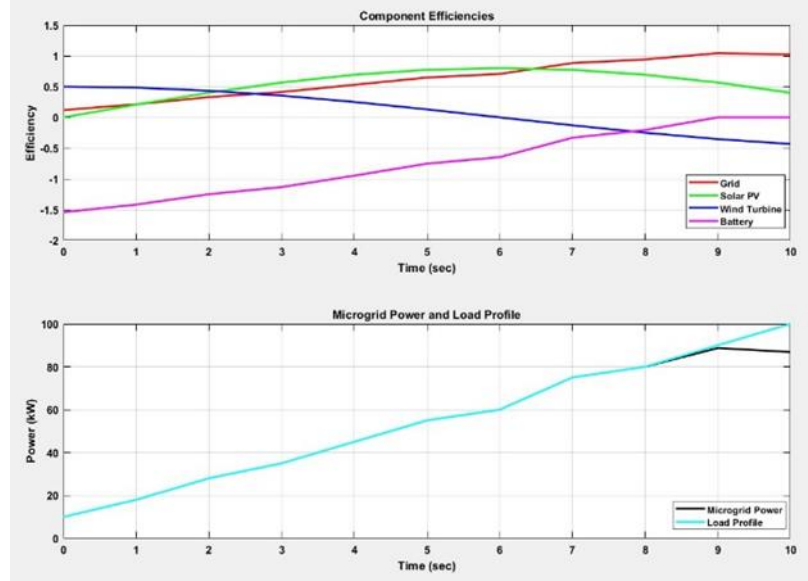

Figure 13. Efficiency and Performance of microgrid components

K. Fuzzy-based PID controller

Figure 14 illustrates the performance variation of a Fuzzy-based PID controller over time, demonstrating an enhancement in system performance. This improvement is attributed to the dynamic adjustment of the controller's parameters, namely K_i , K_p , and K_d , within ranges of 0.024 to 0.032, 0.0015 to -0.0074, and -0.25 to -0.27, respectively. The fluctuations in these parameters indicate the adaptive nature of the Fuzzy-based PID controller, which continuously adjusts its gains to optimize system response. Such adaptability enables the controller to effectively regulate the system, leading to improved stability, accuracy, and overall performance.

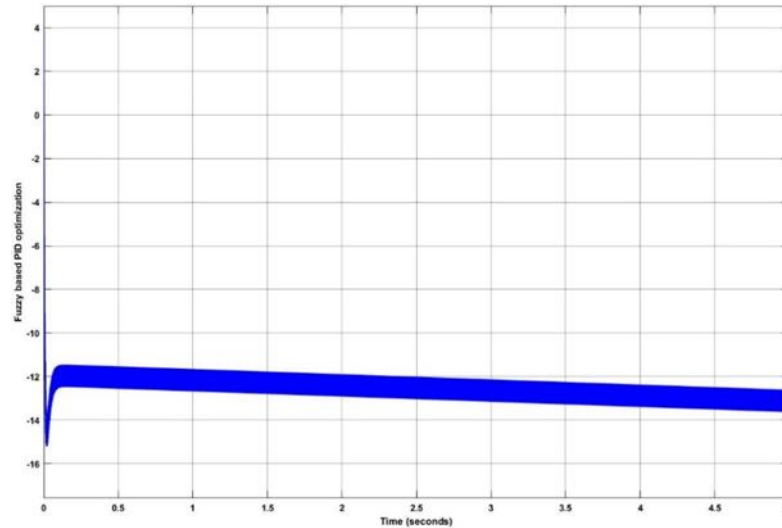

Figure 14. Fuzzy-based PID controller

L. Coordinated Control Voltage

The figure depicts the outcomes of the coordinated control voltage. Initially, the coordinated control voltage gradually increased from 255V to 275V within the first 2s of the experiment. Subsequently, it remained constant after 275V for the rest of the duration. This observation suggests that the PID fuzzy logic-based control effectively regulated the coordinated control voltage to maintain stability and performance within the microgrid system. The steady-state voltage level achieved indicates successful control implementation, highlighting the efficacy of the proposed control strategy in enhancing microgrid stability and performance.

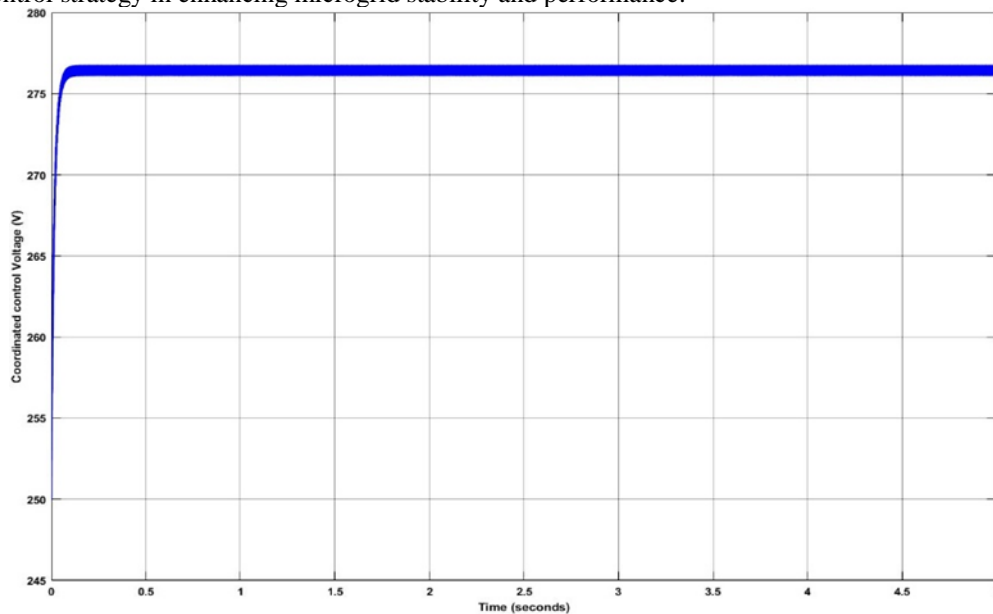

Figure 15. Coordinated control voltage

M. State of Charge

Figure 16 illustrates the SOC of a BESS over 5 seconds. The x-axis denotes time, while the y-axis represents the BESS SOC percentage, ranging from 49.95% to 50%. A decreasing trend in the BESS SOC is observed over time, indicating a reduction in stored energy. The BESS begins with 50% SOC initially and gradually decreases to 49.093% SOC by the end of the 5 seconds. The declining SOC may be attributed to two potential factors: discharging energy to the grid to meet peak demand or providing frequency regulation and self-discharge, which is the natural loss of energy over time even when the battery is not actively in use. This observation underscores the importance of BESS in managing energy supply and demand dynamics, particularly during peak periods.

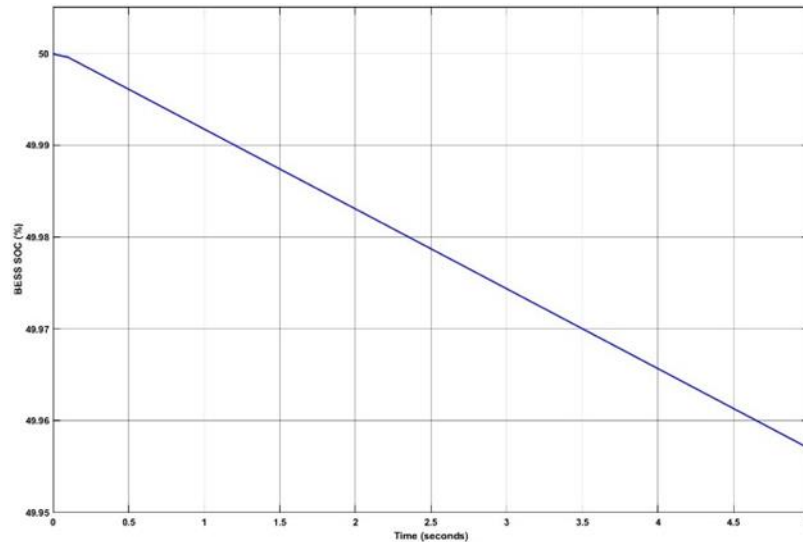

Figure 16. State of charge of BESS

N. Power Profile

The power profile graph for the BESS given in Figure 17 illustrates fluctuations in BESS power over time. The graph exhibits variations in BESS power, fluctuating between 2,000 watts and 5,000 watts. Notably, the power initially starts varying at approximately 3,200 watts, then suddenly stabilizes around 4000W and maintains this level for the rest of the time period. The BESS discharges during high-demand periods and charges during low-demand periods, and frequency regulation, where rapid charging and discharging help to maintain grid frequency within a specific range.

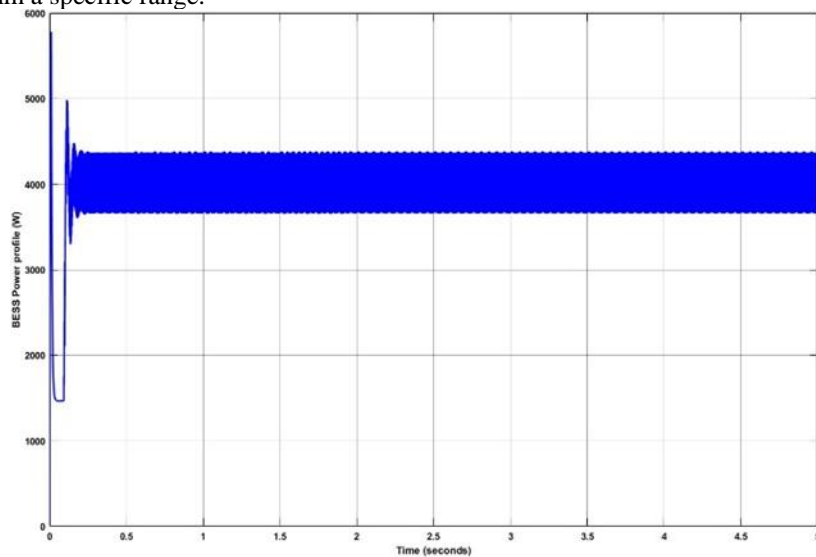

Figure 17. Power Profile for BESS

O. Voltage control

Figure 18 illustrates the voltage of a BESS over time. The BESS Voltage ranges from 25.79V to 25.66V. The graph indicates slight fluctuations in BESS voltage over time. Despite these fluctuations, the BESS voltage remains relatively stable, fluctuating within a range of approximately 25.66V to 25.67V.

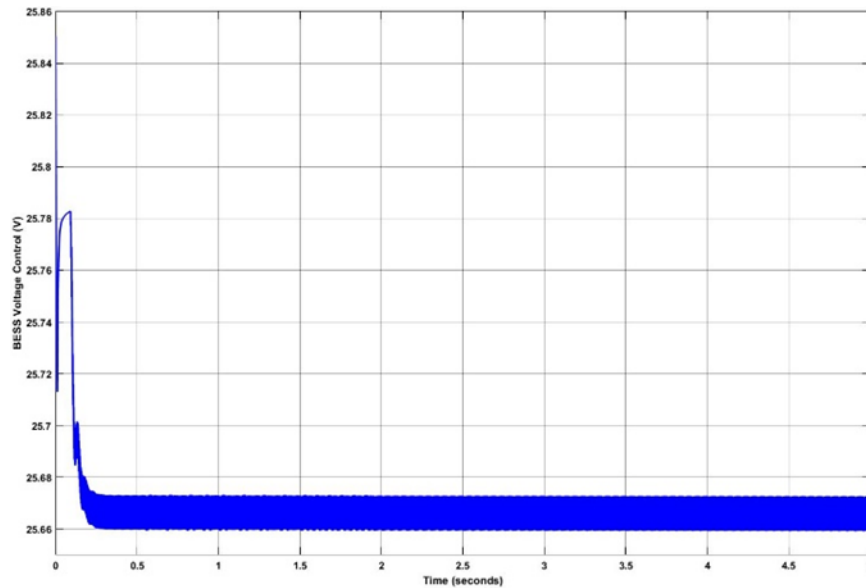

Figure 18. Voltage control of BEES

This stability suggests the proper functioning of the battery and effective voltage control mechanisms in place. Factors influencing battery voltage, such as SOC, charge/discharge rates, and temperature, should also be considered for a holistic understanding of BESS performance.

VI. CONCLUSION

The evaluation of the PID fuzzy logic-based control system in the hybrid microgrid not only demonstrates its effectiveness in enhancing stability and performance but also signifies a significant milestone in the advancement of microgrid technology. By successfully regulating coordinated control voltage and maintaining consistent grid power output, the system showcases its robustness and reliability in managing power dynamics within the microgrid. Furthermore, the stable performance of the wind turbine highlights the efficacy of advanced control strategies in ensuring optimal energy generation from renewable sources. Future research could explore the scalability and scalability of the proposed control system to larger microgrid networks, as well as investigate the integration of emerging technologies such as machine learning and artificial intelligence for even more precise and adaptive control strategies. Additionally, efforts can be directed towards implementing real-time monitoring and predictive maintenance techniques to further enhance the resilience and efficiency of microgrid operations. Overall, the study sets the stage for continued innovation and development in microgrid management, paving the way for sustainable and resilient energy infrastructure in the future.

ACKNOWLEDGMENT

The preferred spelling of the word “acknowledgment” in America is without an “e” after the “g”. Avoid the stilted expression, “One of us (R.B.G.) thanks” Instead, try “R.B.G. thanks”. Put applicable sponsor acknowledgments here; DO NOT place them on the first page of your paper or as a footnote.

REFERENCES

- [1] Yoldaş, Yeliz, Ahmet Önen, S. M. Mueeen, Athanasios V. Vasilakos, and Irfan Alan. "Enhancing smart grid with microgrids: Challenges and opportunities." *Renewable and Sustainable Energy Reviews* 72 (2017): 205-214.
- [2] Nikolaidis, Pavlos, and Andreas Poullikkas. "Sustainable services to enhance flexibility in the upcoming smart grids." *Sustaining resources for tomorrow* (2020): 245-274.
- [3] Vandoorn, Tine L., Lieven Vandeveld, D. Bakken, and K. Iniewski. "Contribution of Microgrids to the Development of the Smart Grid." (2014): 191-212.
- [4] Fadel, Aliaa M., Andrew M. Ibrahim, Ahmed K. Tamazin, Ragi A. Hamdy, and Ayman S. Abdel-Khalik. "Iot-based power management for dc microgrids." In *2019 21st International Middle East Power Systems Conference (MEPCON)*, pp. 1107-1111. IEEE, 2019.
- [5] Molina, Marcelo G. "Energy storage and power electronics technologies: A strong combination to empower the transformation to the smart grid." *Proceedings of the IEEE* 105, no. 11 (2017): 2191-2219.
- [6] Justo, Jackson John, Francis Mwasilu, Ju Lee, and Jin-Woo Jung. "AC-microgrids versus DC-microgrids with distributed energy resources: A review." *Renewable and sustainable energy reviews* 24 (2013): 387-405.
- [7] Naji Alhasnawi, Bilal, Basil H. Jasim, and M. Dolores Esteban. "A new robust energy management and control strategy for a hybrid microgrid system based on green energy." *Sustainability* 12, no. 14 (2020): 5724.

- [8] Ahmed, Ijaz, Muhammad Rehan, Abdul Basit, Hasnain Ahmad, Waqas Ahmed, Nasim Ullah, Marian Piecha, Vojtech Blazek, and Lukas Prokop. "Review on microgrids design and monitoring approaches for sustainable green energy networks." *Scientific Reports* 13, no. 1 (2023): 21663.
- [9] Saeed, Muhammad Hammad, Wang Fangzong, Basheer Ahmed Kalwar, and Sajid Iqbal. "A review on microgrids' challenges & perspectives." *IEEE Access* 9 (2021): 166502-166517.
- [10] Azeroual, Mohamed, Tijani Lamhamdi, Hassan El Moussaoui, and Hassane El Markhi. "Intelligent energy management system of a smart microgrid using multiagent systems." *Archives of electrical engineering* 69, no. 1 (2020): 23-38.
- [11] Voumick, Dipta, Prince Deb, and Mohammad Monirujjaman Khan. "Operation and control of microgrids using IoT (internet of things)." *Journal of Software Engineering and Applications* 14, no. 8 (2021): 418-441.
- [12] Sen, Sachidananda, and Vishal Kumar. "Microgrid control: A comprehensive survey." *Annual Reviews in control* 45 (2018): 118-151.
- [13] Wei, Xu, Xiao Xiangning, and Chen Pengwei. "Overview of key microgrid technologies." *International Transactions on Electrical Energy Systems* 28, no. 7 (2018): e2566.
- [14] Yazdani, Mehrdad, and Ali Mehrizi-Sani. "Distributed control techniques in microgrids." *IEEE transactions on smart grid* 5, no. 6 (2014): 2901-2909.
- [15] Khorsandi, Amir, Mojtaba Ashourloo, and Hossein Mokhtari. "A decentralized control method for a low-voltage DC microgrid." *IEEE Transactions on Energy Conversion* 29, no. 4 (2014): 793-801.
- [16] Chauhan, Rajeev Kumar, Bharat Singh Rajpurohit, Robert E. Hebner, Sri Niwas Singh, and Francisco M. Gonzalez-Longatt. "Voltage standardization of DC distribution system for residential buildings." *CEM Publications* (2014).
- [17] Chauhan, R. K., and B. S. Rajpurohit. "DC distribution system for energy efficient buildings." In *2014 Eighteenth National Power Systems Conference (NPSC)*, pp. 1-6. IEEE, 2014.
- [18] Choi, Jong Chan, Ho Young Jeong, Dong Jun Won, Seon Ju Ahn, and Seung Il Moon. "Cooperative voltage control of distributed generation and grid connected converter in dc microgrid." *Renewable Energy and Power Quality Journal* 1, no. 11 (2013): 989-993.
- [19] Rajamand, Sahbasadat. "Synchronous generator control concept and modified droop for frequency and voltage stability of microgrid including inverter-based DGs." *Journal of Electrical Engineering & Technology* 15, no. 3 (2020): 1035-1044.
- [20] Tayab, Usman Bashir, Mohd Azrik Bin Roslan, Leong Jenn Hwai, and Muhammad Kashif. "A review of droop control techniques for microgrid." *Renewable and Sustainable Energy Reviews* 76 (2017): 717-727.
- [21] Ott, Leopold, Yunchao Han, Bernd Wunder, Julian Kaiser, Fabian Fersterra, Matthias Schulz, and Martin März. "An advanced voltage droop control concept for grid-tied and autonomous DC microgrids." In *2015 IEEE International Telecommunications Energy Conference (INTELEC)*, pp. 1-6. IEEE, 2015.
- [22] Islam, Shirazul, Shyam Agarwal, A. B. Shyam, Anoop Ingle, Soumya Thomas, Sandeep Anand, and Soumya Ranjan Sahoo. "Ideal current - based distributed control to compensate line impedance in DC microgrid." *IET Power Electronics* 11, no. 7 (2018): 1178-1186.
- [23] Benchouia, M. T., I. Ghabbane, A. Golea, Kamel Srairi, and Mohamed El Hachemi Benbouzid. "Implementation of adaptive fuzzy logic and PI controllers to regulate the DC bus voltage of shunt active power filter." *Applied soft computing* 28 (2015): 125-131.
- [24] Davari, Masoud, and Yasser Abdel-Rady I. Mohamed. "Robust droop and DC-bus voltage control for effective stabilization and power sharing in VSC multiterminal DC grids." *IEEE Transactions on Power Electronics* 33, no. 5 (2017): 4373-4395.
- [25] Somefun, Oluwasegun Ayokunle, Kayode Akingbade, and Folasade Dahunsi. "The dilemma of PID tuning." *Annual Reviews in Control* 52 (2021): 65-74.
- [26] Tepljakov, Aleksei, Baris Baykant Alagoz, Celaledin Yeroglu, Emmanuel A. Gonzalez, S. Hassan Hosseinnia, Eduard Petlenkov, Abdullah Ates, and Martin Cech. "Towards industrialization of FOPID controllers: A survey on milestones of fractional-order control and pathways for future developments." *IEEE Access* 9 (2021): 21016-21042.
- [27] Chauhan, Rajeev Kumar, Bharat Singh Rajpurohit, Robert E. Hebner, Sri Niwas Singh, and Francisco MG Longatt. "Design and analysis of PID and fuzzy-PID controller for voltage control of DC microgrid." In *2015 IEEE Innovative Smart Grid Technologies-Asia (ISGT ASIA)*, pp. 1-6. IEEE, 2015.
- [28] Feng, Gang. *Analysis and synthesis of fuzzy control systems: a model-based approach*. Vol. 37. CRC press, 2018.
- [29] Sarkhel, Prasenjit, Nilotpal Banerjee, and Nirmal Baran Hui. "Fuzzy logic-based tuning of PID controller to control flexible manipulators." *SN Applied Sciences* 2 (2020): 1-11.
- [30] Chlahawi, A. A. "Genetic algorithm error criteria as applied to PID controller DC-DC buck converter parameters: an investigation." In *IOP Conference Series: Materials Science and Engineering*, vol. 671, no. 1, p. 012032. IOP Publishing, 2020.
- [31] Sumarmad, Khaizaran Abdulhussein Al, Nasri Sulaiman, Noor Izzri Abdul Wahab, and Hashim Hizam. "Microgrid energy management system based on fuzzy logic and monitoring platform for data analysis." *Energies* 15, no. 11 (2022): 4125.
- [32] Eluri, Himabindu, and M. Gopichand Naik. "Energy management system and enhancement of power quality with grid integrated micro-grid using fuzzy logic controller." *IJEER* 10, no. 2 (2022): 256-263.
- [33] Al Sumarmad, Khaizaran Abdulhussein, Nasri Sulaiman, Noor Izzri Abdul Wahab, and Hashim Hizam. "Energy management and voltage control in microgrids using artificial neural networks, PID, and fuzzy logic controllers." *Energies* 15, no. 1 (2022): 303.
- [34] Alayi, Reza, Farhad Zishan, Seyed Reza Seyednouri, Ravinder Kumar, Mohammad Hossein Ahmadi, and Mohsen Sharifpur. "Optimal load frequency control of island microgrids via a PID controller in the presence of wind turbine and PV." *Sustainability* 13, no. 19 (2021): 10728.
- [35] Sharma, Arvind, Mohan Kolhe, K. M. S. Y. Konara, Nils Ulltveit-Moe, Kapil Muddineni, Ashwini Mudgal, and Shirish Garud. "Performance assessment of institutional photovoltaic based energy system for operating as a micro-grid." *Sustainable Energy Technologies and Assessments* 37 (2020): 100563.
- [36] Elkazaz, Mahmoud, Mark Sumner, Seksak Pholboon, Richard Davies, and David Thomas. "Performance assessment of an energy management system for a home microgrid with PV generation." *Energies* 13, no. 13 (2020): 3436.

- [37] Mohamed, Regad, M. Helaimi, R. Taleb, Hossam A. Gabbar, and Ahmed M. Othman. "Frequency control of microgrid system based renewable generation using fractional PID controller." *Indonesian Journal of Electrical Engineering and Computer Science* 19, no. 2 (2020): 745-755.
- [38] Hemanand, T., N. P. Subramaniam, and M. Venkateshkumar. "Comparative analysis of intelligent controller based microgrid integration of hybrid PV/wind power system." *Journal of Ambient Intelligence and Humanized Computing* (2018): 1-20.
- [39] Mahdi, Mazin Mustafa, and Abu Zaharin Ahmad. "Load frequency control in microgrid using fuzzy logic table control." In 2017 11th IEEE international conference on compatibility, power electronics and power engineering (CPE-POWERENG), pp. 318-323. IEEE, 2017.
- [40] Angalaeswari, S., OV Gnana Swathika, V. Ananthkrishnan, JL Febin Daya, and K. Jamuna. "Efficient power management of grid operated microgrid using fuzzy logic controller (FLC)." *Energy Procedia* 117 (2017): 268-274.
- [41] Mahmoud, Magdi Sadek, S. Azher Hussain, and Mohammad A. Abido. "Modeling and control of microgrid: An overview." *Journal of the Franklin Institute* 351, no. 5 (2014): 2822-2859.
- [42] Lede, Adriel M. Rizzato, Marcelo G. Molina, Maximiliano Martinez, and Pedro E. Mercado. "Microgrid architectures for distributed generation: A brief review." In 2017 IEEE PES Innovative Smart Grid Technologies Conference-Latin America (ISGT Latin America), pp. 1-6. IEEE, 2017.
- [43] Kim, Jong-Yul, Hak-Man Kim, Seul-Ki Kim, Jin-Hong Jeon, and Heung-Kwan Choi. "Designing an energy storage system fuzzy PID controller for microgrid islanded operation." *Energies* 4, no. 9 (2011): 1443-1460.
- [44] Palizban, Omid, Kimmo Kauhaniemi, and Josep M. Guerrero. "Microgrids in active network management—part II: System operation, power quality and protection." *Renewable and Sustainable Energy Reviews* 36 (2014): 440-451.
- [45] GM Abdolrasol, Maher, Mahammad Abdul Hannan, SM Suhail Hussain, Taha Selim Ustun, Mahidur R. Sarker, and Pin Jern Ker. "Energy Management Scheduling for Microgrids in the Virtual Power Plant System Using Artificial Neural Networks." *Energies* 14, no. 20 (2021): 6507.
- [46] Kasimalla, Venkata KoteswaraRao, and Venkateswarlu Velisala. "A review on energy allocation of fuel cell/battery/ultracapacitor for hybrid electric vehicles." *International Journal of Energy Research* 42, no. 14 (2018): 4263-4283.
- [47] Ramya, K. C., and V. Jegathesan. "Comparison of pi and pid controlled bidirectional dc-dc converter systems." *International Journal of Power Electronics and Drive Systems* 7, no. 1 (2016): 56.
- [48] Chen, Zhihuan, Xiaohui Yuan, Bin Ji, Pengtao Wang, and Hao Tian. "Design of a fractional order PID controller for hydraulic turbine regulating system using chaotic non-dominated sorting genetic algorithm II." *Energy Conversion and Management* 84 (2014): 390-404.
- [49] Wang, Lei, Jiayang Liu, Chen Yang, and Di Wu. "A novel interval dynamic reliability computation approach for the risk evaluation of vibration active control systems based on PID controllers." *Applied Mathematical Modelling* 92 (2021): 422-446.
- [50] Kala, H., D. Deepakraj, P. Gopalakrishnan, P. Vengadesan, and M. Karumbal Iyyar. "Performance evaluation of fuzzy logic and PID controller for liquid level process." *Perform. Eval* 2, no. 3 (2014).
- [51] Ray, Prakash K., Shiba R. Paital, Asit Mohanty, Foo YS Eddy, and Hoay Beng Gooi. "A robust power system stabilizer for enhancement of stability in power system using adaptive fuzzy sliding mode control." *Applied Soft Computing* 73 (2018): 471-481.