

Jaya Vani Lagudu<sup>1</sup>,  
K.  
Jithendra Gowd<sup>2</sup>,  
S. Satyanarayana<sup>3</sup>

## Power Sharing in interconnected Ring Main DC Micro Grids with Dual Active Bridge Configuration



**Abstract:** - While the techno-economic feasibility of Solid State Transformers (SSTs) is still being debated, some significant power industry corporations have recognized their potential and begun commercialization. One of SST's key benefits is its ability to incorporate low-voltage DC grid technologies. An important research priority in this sector is the creation of an accurate SST model for efficient power transmission between two DC grids. This article describes an exact composite SST model that has a high switching frequency. The model is regulated using both a traditional voltage control approach and a new power control mechanism. The developed SST is used in a dual active bridge arrangement to transmit power between two interconnected ring main DC microgrids, which contain distributed energy resources. Furthermore, this study presents a thorough examination of the power-sharing strategy amongst interconnected microgrids while guaranteeing that individual bus voltages remain within mandated limits using a supervisory communication control technique.

**Keywords:** mandated, transmit, guaranteeing, arrangement

### 1. Introduction

The changing structure of traditional power networks creates several obstacles for establishing power system infrastructure. Traditional distribution systems use distribution transformers to reduce high transmission or sub-transmission voltages so that power may be distributed at lower levels. However, as dispersed generation becomes more widely used, new issues in the design and maintenance of distribution transformers emerge. Advances in power electronics have made it possible to develop unique converter-based solutions to meet a variety of power system difficulties. One type of converter-based transformer is the Solid-State Transformer (SST), which is meant to address the constraints of traditional distribution transformers while providing a system architecture that is compatible with current distribution networks. Historically, the worldwide tendency has been to construct vertically integrated utilities, with the government owning and regulating the majority of power system infrastructure. However, several nations have enacted deregulation laws to promote private sector investments in the power sector in order to fulfill the growing demand for electricity. Distributed generation (DG), or small-scale electricity generation at the distribution level, has emerged as a result of this change. Energy storage and responsive loads, often known as distributed energy resources (DER), were added to the definition of distributed generation (DG) throughout time. A microgrid is created when DERs are paired with energy storage and control technologies.

The entire complexity is increased by the fact that many energy storage systems and renewable energy sources (RES) use power electronic interfaces for grid integration (Anees, 2012). Power quality issues including voltage variations and harmonic distortions are more noticeable in distribution networks with a high distributed generation (DG) penetration rate (Prabhala, Baddipadiga, & Ferdowsi, 2014). The distribution network's current harmonics cause higher operating temperatures and more energy losses in distribution transformers, which shortens their lifespan (Arrillaga, Bollen, & Watson, 2000; Said & Nor, 2008). The use of semiconductors in high-voltage and high-power systems has been made easier by technological advancements. Elmoudi, Lehtonen, and Nordman (2006) offer a thorough synopsis of these

<sup>1</sup>Jaya Vani Lagudu<sup>1</sup>, K. Jithendra Gowd<sup>2</sup>, S. Satyanarayana<sup>3</sup>

<sup>1</sup>Research Scholar, JNTUA, Anantapur, India

<sup>2</sup>Associate Professor, JNTUA, Anantapur, India

<sup>3</sup>Professor, Department of EEE, Raghu Institute of Technology, Anantapur, India

Email id: 1jayavanilagudu@gmail.com, 2indra.eee@jntua.ac.in, 3ssn\_professoreee@yahoo.com

advancements for these kinds of uses. Two industrial Solid-State Transformer (SST) unit prototypes are now available in the literature.

The use of Solid-State Transformers (SST) in microgrids is examined in this section. Because of their ability to generate and distribute power locally, microgrids are becoming more and more popular. The two main categories into which they fall are (i) AC microgrids and (ii) DC microgrids. It is commonly known that DC microgrids are superior to their AC equivalents (Dragičević et al., 2015). The smooth integration of DC microgrids with renewable energy sources like fuel cell (FC), battery energy storage (BESS), and solar photovoltaic (SPV) systems is one of their main advantages.

According to Dragičević et al. (2016), DC microgrid distribution systems usually have one of two architectures: (i) radial type or (ii) ring main type. Due to its capacity to sustain constant power delivery even in the event of a fault, ring main microgrids are typically chosen over radial layouts. Due to its unique benefits, DC microgrid interconnection is growing in popularity (Mudaliyar & Mishra, 2017). Power converters or SST are two ways to connect these microgrids (Blaabjerg et al., 2006).

Yu et al. (2014) describe a power management strategy for SST-based microgrids that uses a droop control approach for the battery and SST. This technique, however, is restricted to microgrids of the radial kind and concentrates on local control mechanisms rather than on the function of a central controller. In addition, Yu et al. (2014) talk about the effects of PV power on the grid and a hybrid microgrid architecture that combines both AC and DC distribution networks. Nevertheless, the report doesn't discuss the converters' communication tactics. This paper investigates an interconnected ring main DC grid with a coordinated voltage and power regulation method in order to overcome these constraints. Furthermore, the suggested system enables global control via a supervisory communication technique while integrating local control at each converter. Simulations and experimental analysis are used to validate the effectiveness of the suggested system, and the results are described in detail. The sections that follow provide an overview of this study's main contributions.

The following are this work's primary contributions:

- (i) Solid-State Transformer (SST) Design, Modeling, and Control: This involves creating a precise dynamic model of the SST that can be used to investigate its dynamic performance and stability.
- (ii) SST Application in Power Sharing Among Interconnected DC Microgrids: SST is used to effectively transmit power between interconnected DC microgrids, each of which include loads, solar photovoltaic systems, and battery energy storage systems.
- (iii) Coordinated Voltage and Power Control Strategy: This involves developing a control plan to manage the flow of power and voltage in the suggested microgrid architecture.
- (iv) Developing a Supervisory Control Approach: A supervisory communication-based control system is established to manage the two DC microgrids' power exchange.

## 2. Modelling, design and control of SST

The number of switches in the bridge circuit exactly correlates with the power transferred via an isolated bidirectional DC-DC converter. The Dual Active Bridge (DAB) is a tiny filter-equipped isolated bidirectional DC-DC converter with a high power capacity. As shown in

Figure 1, the DAB configuration is made up of two H-bridge inverters, two DC link capacitors, an auxiliary inductor, and a high-frequency transformer.

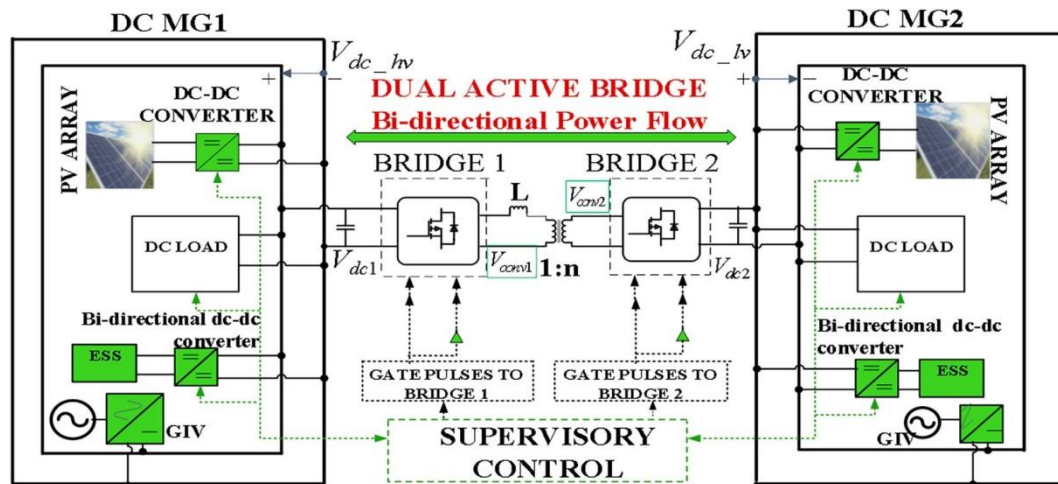

Fig.(1) Ring Main DC Micro Grid with Dual Active Bridge Converter

The fundamental AC voltage on the converter side is given by (1),

$$V_{conv1} = \frac{2\sqrt{2}}{\pi} mV_{dc} \quad (1)$$

Equation (2) shows that the first DAB converter, also referred to as the leading bridge, leads the other converter, sometimes referred to as the lagging bridge, in the direction of power flow by a specific phase difference.

$$P_{dc} = \frac{V_{dc\_hv} V_{dc\_lv}}{n2\pi^2 f_s L} \varphi(\pi - \varphi) \quad (2)$$

The primary side DC-link voltage is set to 3400 V for simulation and illustration purposes, while the secondary side DC-link voltage is set to 425 V. Finding the SST's voltage transformation ratio and the primary side DC-link voltage design value is the next stage. First, a traditional constant voltage control approach is shown, and then a power control method that may be applied to a distribution system with various control goals is suggested. High-frequency transmission greatly improves the converter's density and flexibility. Single phase shift (SPS) control can be used to characterize the power transmission in a DAB.

### 3. Dual active bridge control

Depending on the state variable to be regulated, two control strategies are suggested. The traditional approach suggests employing phase difference as a control input to keep the DC-link voltage on the secondary side constant. When a non-inertial energy source (like a photovoltaic plant) or a simple load is connected at the DC-link and is unable to sustain the DC-link voltage on its own, this technique can be helpful. However, as previously mentioned, a DC-AC converter can be used to maintain the DC-link voltage when there is an inertial energy source present, such as a synchronous generator, wind farm, or energy storage device.

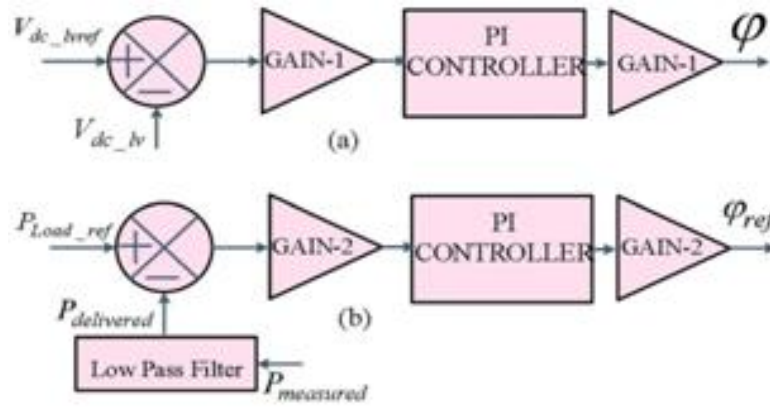

Figure 2. (a) Voltage control (b) Power control schematic.

Fig. (3) compiles the simulation findings for a few of the crucial SST parameters. In order to assess system stability, the system is also exposed to a load change at various intervals.

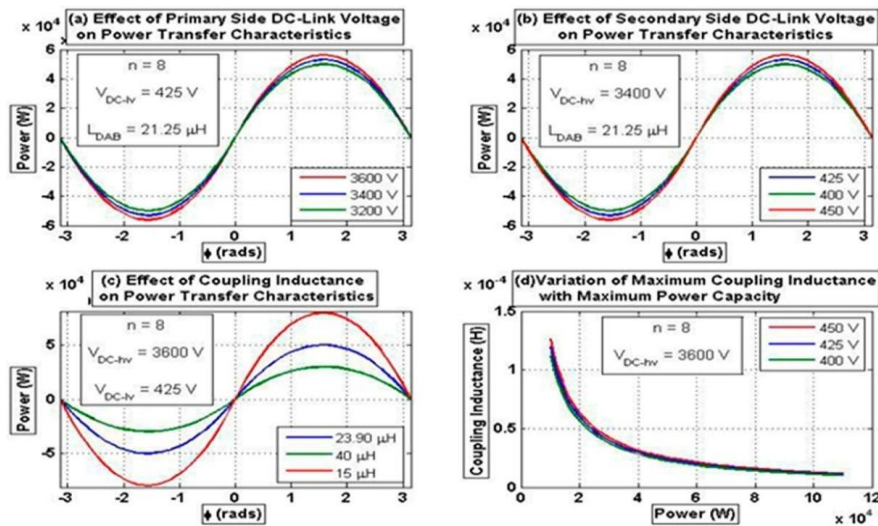

Figure 3. Power characteristics of a dual active bridge.

#### 4. Application of SST in microgrid system

DC MG1 and DC MG2 are the designations given to the proposed DC microgrid. SPV, ESS, grid-connected inverter (GIV), and local loads make up DC MG1, while DC MG2 has all of the same resources minus GIV. Every DER has its own local control, which is in charge of either bus voltage control or current control (a thorough analysis is provided in the following section). In DC MG1 and DC MG2, the bus voltage is maintained by the ESS, and the SPV runs in current control mode to guarantee that the SPV panel extracts the most power possible. The server, which serves as supervisory control and provides the required instructions for local control to follow, receives all voltage and current data.

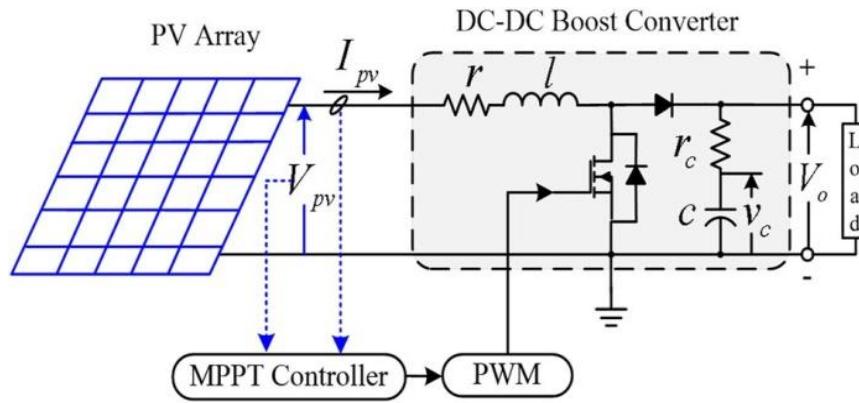

Fig. 4. Implemented PV system with current and voltage sensors.

The basic component used to produce a PV module is a linked PV cell. PV modules can be joined in series to increase output voltage and in parallel to increase output current, resulting in a PV array. A PV array's power production is extremely susceptible to external conditions like temperature and irradiance. The maximum power point (MPP) changes from cell to cell because PV cell characteristics are nonlinear. Nonetheless, a PV array displays a distinct maximum power point for that particular environment when exposed to homogenous irradiation.

Maximum Power Point Tracking (MPPT) techniques are essential for optimizing power extraction and making sure the PV array runs as efficiently as possible. The basic current equation that governs the model of PV arrays is given in equation (5).

$$I_{pv} = I_{sc} - I_0 \left\{ \exp \left( \frac{q(V_{pv} + I_{pv}R_s)}{N_sAK_bT} \right) - 1 \right\} - \left( \frac{V_{pv} + I_{pv}.R_s}{R_{sh}} \right) \tag{5}$$

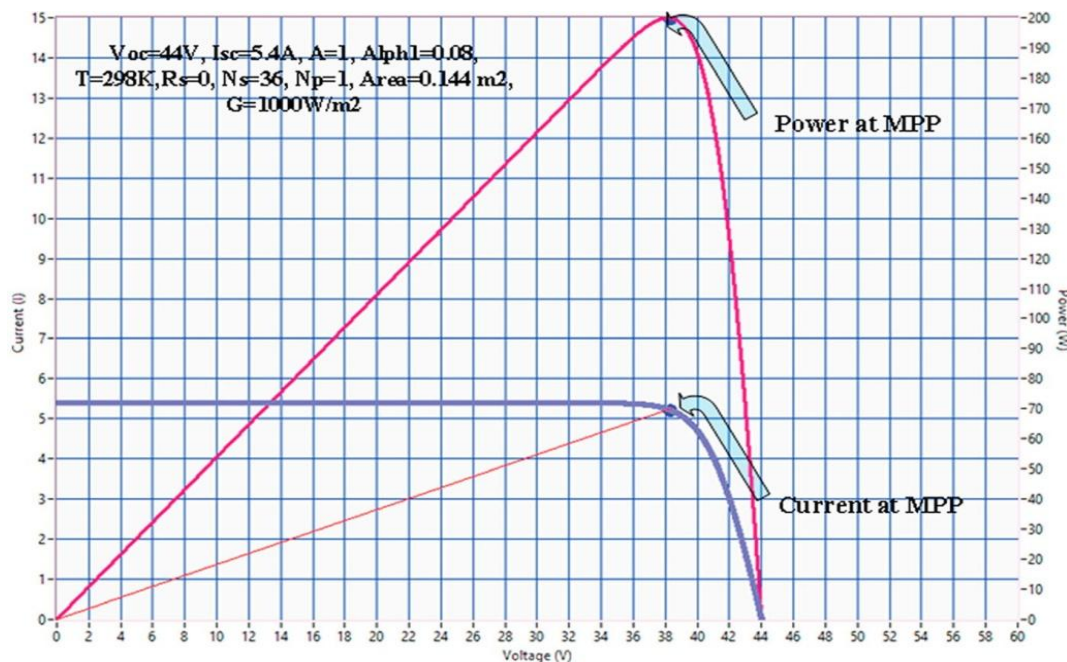

Fig.5. PV emulator I-V and P-V characteristics with load line and MPP(maximum power point).

Where  $q$  is the charge of the electron  $=1.602 \times 10^{-19} \text{C}$ ,  $K_b = 1.38 \times 10^{-23} \text{J/K}$  (Boltzmann constant),  $T$  = Junction temperature in K,  $A$  = Diode factor ( $\approx 1$ ),  $V_{pv}$  = Output voltage of PV panel,  $V_{oc}$  = Open circuit voltage,  $I_{pv}$  = Output current of PV panel;  $I_0$  = Diode saturation current;  $I_{sc}$  = Short circuit current;  $I_{ph}$  = Photo generated current;  $R_s$  = equivalent series resistance in  $Q$ ;  $R_{sh}$  equivalent parallel resistance in  $Q$ ,  $N_s$  Number of series cells. (All parameters are given in Fig.5).

## 5. Conclusion

The design, modeling, and control of SST for networked dc microgrids are presented in this article. A developed supervisory control approach between two DC microgrids has been used to implement a coordinated voltage and power control strategy for the proposed design. Additionally, the system has been evaluated for abrupt changes in irradiation and load. Results from experiments demonstrate that the system is stable and maintains the DC bus voltage even in the face of abrupt changes. Additionally, a power control strategy is created for both power and voltage control. Additionally, the system has been tested and found to be stable when a 3.5 millisecond communication delay is introduced.

## References

1. Anees, Ahmed Sharique. 2012. "Grid Integration of Renewable Energy Sources: Challenges, Issues and Possible Solutions." 2012 IEEE 5th India International Conference on Power Electronics (IICPE), Delhi, India, 1–6.
2. Arrillaga, J., M.H.J. Bollen, and N.R. Watson. 2000. "Power Quality Following Deregulation." *Proceedings of the IEEE* 88 (2): 246–261.
3. Biela, Juergen, Mario Schweizer, Stefan Waffler, and Johann W. Kolar. 2011. "SiC Versus Si Evaluation of Potentials for Performance Improvement of Inverter and DC–DC Converter Systems by SiC Power Semiconductors." *IEEE Transactions on Industrial Electronics* 58 (7): 2872–2882.
4. Blaabjerg, F., R. Teodorescu, M. Liserre, and A. V. Timbus. 2006. "Overview of Control and Grid Synchronization for Distributed Power Generation Systems." *IEEE Transactions on Industrial Electronics* 53 (5): 1398–1409.
5. Chung, S.-K. 2000. "Phase-locked Loop for Grid-Connected Three-Phase Power Conversion Systems." *IEEE Proceedings—Electric Power Applications* 147 (3): 213–219.
6. Davoudi, A., and J. Jatskevich. 2006. "Realization of Parasitics in State-Space Average-Value Modeling of PWM DC-DC Converters." *IEEE Transactions on Power Electronics* 21 (4): 1142–1147, July.
7. Dragičević, T., X. Lu, J. C. Vasquez, and J. M. Guerrero. 2015. "DC Microgrids Part I: A Review of Control Strategies and Stabilization Techniques." *IEEE Transactions on Power Electronics* 31 (7): 4876–4891.
8. Dragičević, T., X. Lu, J. C. Vasquez, and J. M. Guerrero. 2016. "DC Micro-grids—Part II: A Review of Power Architectures, Applications, and Standardization Issues." *IEEE Transactions on Power Electronics* 31 (5): 3528–3549, May.
9. El-Khattam, W., and M. M. A. Salama. 2004. "Distributed Generation Technologies, Definitions and Benefits, ELSEVIER." *Electric Power Systems Research* 71 (2): 119–128, October.

9. El-Khattam, W., and M. M. A. Salama. 2007. "Integrating Distributed Generation Into Electric Power Systems: A Review of Drivers, Challenges and Opportunities", ELSEVIER." *Electric Power Systems Research* 77 (9):1189-1203, July.
10. Elliman, Ryan, Christopher Gould, and Moofik Al-Tai. 2015. "Review of Current and Future Electrical Energy Storage Devices." Power Engineering Conference (UPEC), 2015 50th International Universities, Stoke on Trent, UK, 1-5.
11. Elmoudi, A., M. Lehtonen, and H. Nordman. 2006. "Effect of Harmonics on Transformers Loss of Life." Conference Record of the 2006 IEEE International Symposium on Electrical Insulation, Toronto, ON, 408-411.
12. Kollimalla, S. K., and M. K. Mishra. 2014. "A Novel Adaptive P&O MPPT Algorithm Considering Sudden Changes in the Irradiance." *IEEE Transactions on Energy Conversion* 29 (3): 602-610, September.