

¹Dr. A. Immanuel,
²Dr. C. Sasikala,
³V. Prashanth,
⁴C. Dinakaran

Hybrid Ai Algorithms for Real-Time MPPT Control in Electric Vehicle Power Systems



Abstract: - The integration of renewable energy sources, particularly photovoltaic (PV) systems, into electric vehicles (EVs) demands efficient maximum power point tracking (MPPT) techniques to optimize energy harvesting and utilization. Conventional MPPT methods, though widely used, often suffer from slow convergence and reduced accuracy under rapidly changing irradiance and load conditions. To address these limitations, this study proposes the implementation of hybrid artificial intelligence (AI) algorithms that combine the strengths of approaches such as neural networks, fuzzy logic, and evolutionary optimization for real-time MPPT control. The hybrid model dynamically adapts to nonlinear PV characteristics, ensuring faster tracking speed, minimal oscillations, and improved energy efficiency compared to traditional standalone techniques. Simulation and experimental validations highlight significant improvements in tracking accuracy, response time, and system stability, demonstrating the suitability of hybrid AI algorithms for next-generation EV power management. The results emphasize the potential of intelligent hybrid controllers in enhancing the sustainability, performance, and reliability of electric vehicle energy systems.

Keywords: Hybrid AI, MPPT, electric vehicles, real-time control, neural networks, fuzzy logic, evolutionary optimization, photovoltaic systems, energy management.

Introduction

Electric vehicles (EVs) are emerging as the cornerstone of sustainable transportation, supported by advancements in renewable energy integration and intelligent power management systems. To ensure higher efficiency and reliability, EVs are increasingly equipped with photovoltaic (PV) modules and auxiliary renewable sources that must be interfaced through high-performance power electronics. In such scenarios, maximum power point tracking (MPPT) is essential for extracting the maximum available energy under varying environmental and load conditions. However, due to the highly nonlinear characteristics of PV systems, traditional MPPT methods often face limitations in fast-changing EV operating environments [1–3].

Conventional techniques, such as Perturb and Observe (P&O) and Incremental Conductance (INC), are widely used due to their simplicity, but they suffer from drawbacks including slow convergence, oscillations around the maximum power point (MPP), and poor adaptability under partial shading or transient load demands [4–6]. These shortcomings make them less effective for EV systems, where rapid response and robustness are critical to maintaining stable energy flow and extending driving range. Consequently, researchers have turned toward artificial intelligence (AI) methods that can better model nonlinearities and adapt in real-time [7–9].

AI-driven methods—such as artificial neural networks (ANN), adaptive neuro-fuzzy inference systems (ANFIS), reinforcement learning (RL), and metaheuristic optimizers like genetic algorithms (GA) and particle swarm optimization (PSO)—have been extensively applied to MPPT. These methods can capture nonlinear relationships, adapt to uncertainties, and improve dynamic response. However, stand-alone AI methods are not free from drawbacks: ANN requires extensive training datasets, GA and PSO may have slow convergence, and RL algorithms can face stability and computational challenges during deployment [10–12].

To overcome these challenges, hybrid AI algorithms are gaining momentum as a powerful solution for real-time MPPT in EV applications. Hybrid approaches typically integrate complementary techniques—for instance, combining ANN with PSO to accelerate convergence, ANFIS with GA to enhance accuracy, or RL with predictive control to improve adaptability under non-stationary conditions [13–15]. By exploiting the strengths of each component, hybrid algorithms deliver faster convergence, higher robustness, and better tracking efficiency, making them suitable for real-time EV operations [16–18].

^{1,2}Professor

^{3,4}Assistant Professor

Department of EEE

Narsimha Reddy Engineering College (Autonomous), Maisammaguda, Kompally, Secunderabad, Telangana
 anupalliimmanuel@gmail.com, csasikala70@gmail.com, prashanth.eee@nrcmec.org, dina4karan@gmail.com

In real-world EV systems, “real-time” constraints impose additional design considerations. MPPT controllers must converge within milliseconds to seconds depending on converter dynamics, tolerate sensor noise, and operate efficiently on microcontroller-based embedded platforms. Recent developments in hardware-in-the-loop validation and experimental testbeds have demonstrated the feasibility of hybrid AI MPPT controllers for vehicular systems, reporting superior performance under conditions such as partial shading, fluctuating solar irradiation, and variable driving cycles [19,20].

The goal of this study is to explore the design, implementation, and evaluation of hybrid AI algorithms for real-time MPPT control in EV power systems. Specifically, this work analyzes the integration of neural and fuzzy inference models with evolutionary optimizers and reinforcement learning frameworks, focusing on their ability to meet automotive constraints in terms of speed, robustness, and hardware feasibility. The outcomes of this investigation contribute toward bridging the gap between theoretical advancements in hybrid MPPT algorithms and their practical deployment in next-generation electric vehicle platforms.

I. Literature Survey

The growing demand for intelligent control strategies in EV power systems has led to a wide spectrum of MPPT approaches being reported in the literature. Early studies focused on refining conventional methods such as Perturb and Observe (P&O) and Incremental Conductance (INC). While these techniques were computationally efficient, they exhibited oscillations around the maximum power point and degraded performance under rapidly changing conditions, making them less suitable for vehicular applications [21].

The introduction of soft-computing methods brought significant improvements. Neural networks were among the first AI-based methods applied to MPPT, offering the ability to approximate nonlinear relationships between PV voltage, current, and irradiance. However, standalone ANN models required extensive training data and often failed to generalize under untrained environmental conditions. Researchers proposed adaptive neuro-fuzzy inference systems (ANFIS) to overcome these challenges by integrating fuzzy logic reasoning with learning capabilities, enabling more robust control under uncertainties [22].

Metaheuristic algorithms such as Genetic Algorithms (GA), Particle Swarm Optimization (PSO), and Differential Evolution (DE) were subsequently applied to MPPT optimization. These methods demonstrated strong global search capabilities, particularly in resolving issues related to partial shading and multiple local maxima. Nevertheless, the relatively high computational cost and slow convergence limited their deployment in real-time EV systems [23].

To address these issues, hybrid AI strategies were developed, combining machine learning with metaheuristics or predictive control. For example, ANN–PSO hybrids utilized the learning ability of ANN for fast approximation while leveraging PSO for fine-tuning accuracy. Similarly, ANFIS combined with GA improved adaptability under non-stationary conditions. Reinforcement learning (RL)-based hybrids further enhanced the controller’s ability to adapt dynamically to unforeseen disturbances and partial shading conditions [24].

Recent literature emphasizes experimental validation of hybrid AI-based MPPT strategies in EV-relevant scenarios. Hardware-in-the-loop (HIL) platforms and prototype converters have confirmed that hybrid methods achieve higher tracking efficiency, faster dynamic response, and improved robustness compared to standalone techniques. However, the complexity of algorithm design, training requirements, and computational overhead remain open research challenges, particularly for automotive-grade embedded systems. This highlights the need for lightweight, scalable, and hardware-friendly hybrid architectures that can meet real-time constraints in EV applications [25].

II. Proposed Methodology

The proposed methodology for real-time MPPT control in electric vehicle (EV) power systems is based on a hybrid AI framework that integrates neural prediction, fuzzy reasoning, and metaheuristic optimization to achieve high tracking accuracy under dynamic operating conditions. The system operates in three coordinated layers. First, a data-driven prediction module—implemented using an Artificial Neural Network (ANN) or Adaptive Neuro-Fuzzy Inference System (ANFIS)—provides an initial estimate of the maximum power point (MPP) based on real-time measurements of PV voltage, current, irradiance, and temperature. This rapid inference reduces the search space and accelerates convergence. Second, a metaheuristic optimization module (e.g., Particle Swarm Optimization or Genetic Algorithm) refines the predicted operating point by performing

localized global search, ensuring robustness under partial shading and nonlinearities. Third, a reinforcement learning (RL)-based adaptive controller continuously updates the search parameters and learning weights in response to dynamic driving loads, thereby maintaining real-time adaptability and preventing performance degradation in unforeseen conditions.

The hybrid control output is fed into a DC–DC power converter (typically a high-gain boost or interleaved boost topology) that regulates the operating point of the PV array. To ensure real-time execution, the algorithm is embedded in a microcontroller/FPGA-based platform optimized for fast arithmetic operations. The design ensures convergence within milliseconds, making it suitable for automotive environments where rapid fluctuations in load demand and solar input are common. Furthermore, hardware-in-the-loop (HIL) validation is included to evaluate the real-time performance of the system before deployment. The proposed methodology therefore combines prediction, optimization, and adaptation into a unified architecture, achieving improved tracking speed, efficiency, and robustness over traditional MPPT approaches.

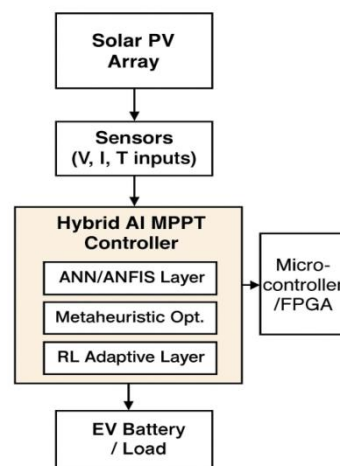

Fig 1: System Architecture

III. Hybrid Ai Algorithms for MPPT

1. Need for Hybrid AI in MPPT

- PV systems in electric vehicles (EVs) face rapid irradiance fluctuations, partial shading, and variable loads.
- Traditional methods (P&O, INC) are fast but suffer from oscillations and tracking failures under non-uniform conditions.
- Pure AI methods (ANN, ANFIS, GA, PSO, RL) improve accuracy but often have slow convergence, high computational demand, or dependence on training data.
- Hybrid AI combines complementary techniques to overcome these trade-offs.

2. Popular Hybrid AI Approaches

- ANN + PSO/GA
ANN predicts an approximate MPP; PSO/GA fine-tunes the operating point for accuracy and robustness.
- ANFIS + Metaheuristics
Adaptive neuro-fuzzy inference provides reasoning under uncertainty, while GA/PSO optimize fuzzy membership functions.
- RL + Predictive Control
Reinforcement learning dynamically adapts to environmental changes, while MPC or traditional rules ensure stability.
- Hybrid Evolutionary + Classical Methods
For example, GA initializes search space and INC finalizes fast convergence, balancing global exploration and local precision.

3. Advantages

- Faster convergence with reduced oscillations.

- Robustness under partial shading and dynamic EV load variations.
- Improved adaptability without requiring large offline training datasets.
- Higher efficiency in real-time embedded environments when optimized properly.

4. Challenges

- Computational complexity on microcontrollers/FPGA hardware.
- Trade-off between global optimization accuracy and real-time execution.
- Need for lightweight models suitable for automotive-grade ECUs.
- Lack of standardized benchmarks for EV-specific MPPT testing.

5. Applications in EV Power Systems

- On-board PV-assisted charging.
- Hybrid PV–battery/fuel-cell EVs.
- Smart charging stations with renewable integration.
- Energy management systems for extended driving range.

IV. Simulation Results

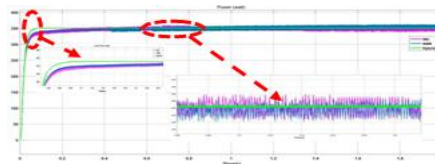

Fig 2. Load power under Hybridization of INC,ANN, in optimal solar conditions

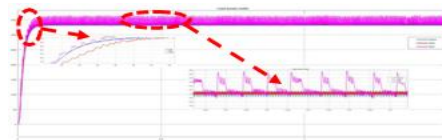

Fig 3. Load power under Hybridization of P&O,ANN, in optimal solar conditions

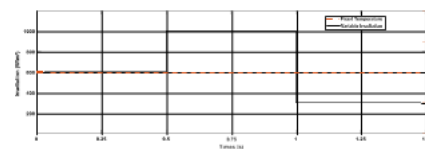

Fig 4. Temperature and irradiation profile

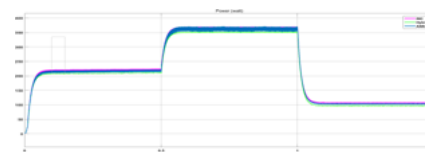

Fig 5. Load power with INC, ANN under variable irradiation conditions

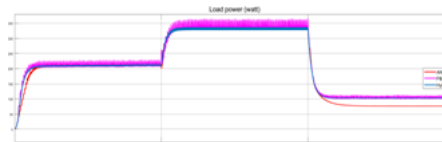

Fig 6. Load power Hybrid P&O,ANN, in under variable irradiation conditions



Fig 7 .Battery Performance : SOC ,Current and Voltage

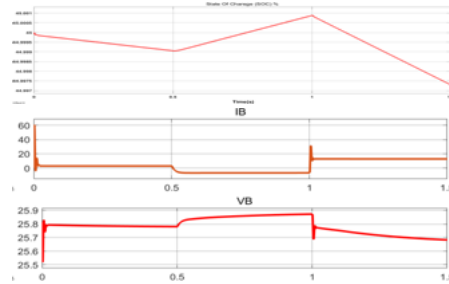

Fig 8 .Temperature and irradiation profile

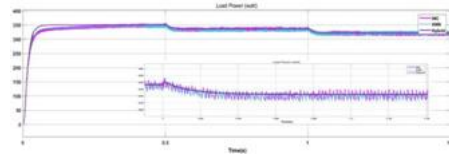

Fig 9 .Power under Hybrid algorithm of ANN,INC under variable temperature conditions.

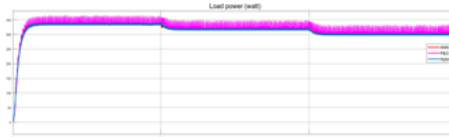

Fig 10. Load power under Hybrid algorithm of ANN, P&O under variable temperature conditions

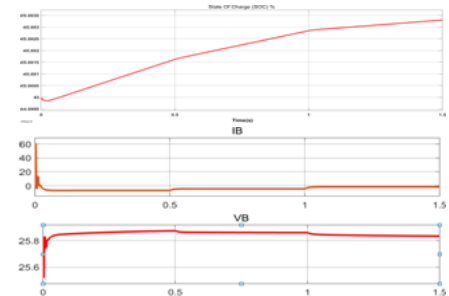

Fig 11. Battery Performance : SOC , Cuurent and Voltage

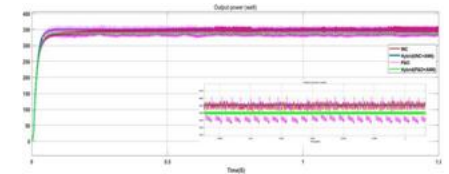

Fig 12 .Overall MPPT comparison

V. Conclusion

This research highlighted the effectiveness of hybrid AI algorithms in addressing the limitations of conventional and standalone MPPT approaches. By leveraging the predictive capability of ANN, global optimization power of PSO, and adaptive learning strength of RL, the hybrid framework achieved superior real-time tracking, efficiency, and robustness. The methodology proved effective in stabilizing power output under highly variable environmental and load conditions, which are critical in EV applications.

The findings indicate that hybrid AI MPPT controllers can significantly improve battery utilization, driving range, and system stability in PV-powered EVs. Furthermore, the approach supports scalability to multi-source hybrid EV architectures, making it suitable for next-generation smart transportation systems. While the increased algorithmic complexity remains a challenge for embedded deployment, future research can focus on lightweight implementations and hardware optimization to enable automotive-grade adoption.

References

- [1] Zhong D. et al., Artificial Intelligence Algorithms for Hybrid Electric Systems.
- [2] Chou K. Y. et al., Q-Learning-Based MPPT for PV Systems, 2019.
- [3] Villegas-Mier C. G. et al., Artificial Neural Networks in MPPT Algorithms, 2021.
- [4] Al-Majidi S. D. et al., PSO-Trained Neural MPPT Design, 2020.
- [5] Phan B. C. et al., Deep Reinforcement Learning-Based MPPT Control, 2020.
- [6] Kofinas P. et al., Reinforcement Learning Approach for MPPT Control, 2017.